

Schémas pour quelques gammes au trombone

Table des matières

- [Fonctionnement des schémas](#)
- [Gammes chromatiques \(asc - desc\)](#)
- [Notes par nombre de positions](#)
- Gammes majeures : [C-D_b-D-E_b-E-F-F[#]-G_b-G-A_b-A-B_b-B](#)
- Pentas majeures : [C-D_b-D-E_b-E-F-F[#]-G_b-G-A_b-A-B_b-B](#)
- Triades majeures : [C-D_b-D-E_b-E-F-F[#]-G_b-G-A_b-A-B_b-B](#)
- Gammes mineures : [C-C[#]-D-D[#]-E_b-E-F-F[#]-G-G[#]-A-B_b-B](#)
- Pentas mineures : [C-C[#]-D-D[#]-E_b-E-F-F[#]-G-G[#]-A-B_b-B](#)
- Triades mineures : [C-C[#]-D-D[#]-E_b-E-F-F[#]-G-G[#]-A-B_b-B](#)
- [Ruses](#)
 - [Do, Ré, Mi](#)
 - [Si, Do, Ré, Mi, Fa](#)
 - [Fa, La, Do](#)
 - [Penta mineure](#)
- [Topologie du trombone](#) (visualisation des positions alternatives)
- [Contact](#)

Fonctionnement des schémas

La coulisse est représentée par un trait vertical, position 1 en bas, position 7 en haut. Des petits marqueurs indiquent les positions 3 et 5.

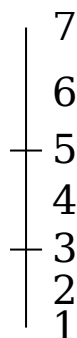

Comme sur le trombone, les positions vont en s'écartant.

Un point de couleur indique à la fois :

- la position à donner à la coulisse ;
- l'harmonique à laquelle se situe la note (code couleur ci-dessous).

 1^{re} harmonique (tonique)

 2^e harmonique (quinte)

 3^e harmonique (octave)

 4^e harmonique (tierce majeure de l'octave)

 5^e harmonique (quinte de l'octave)

 6^e harmonique (septième mineure de l'octave)

 7^e harmonique (octave de l'octave)

 8^e harmonique (seconde 2 octaves au dessus)

 9^e harmonique (tierce majeure hyper haute)

 10^e harmonique (quarte augmentée hyper haute)

Toutes les positions alternatives sont proposées, la position la plus petite est mise en évidence.

Gamme chromatique

Il y a 44 notes pour 31 positions.

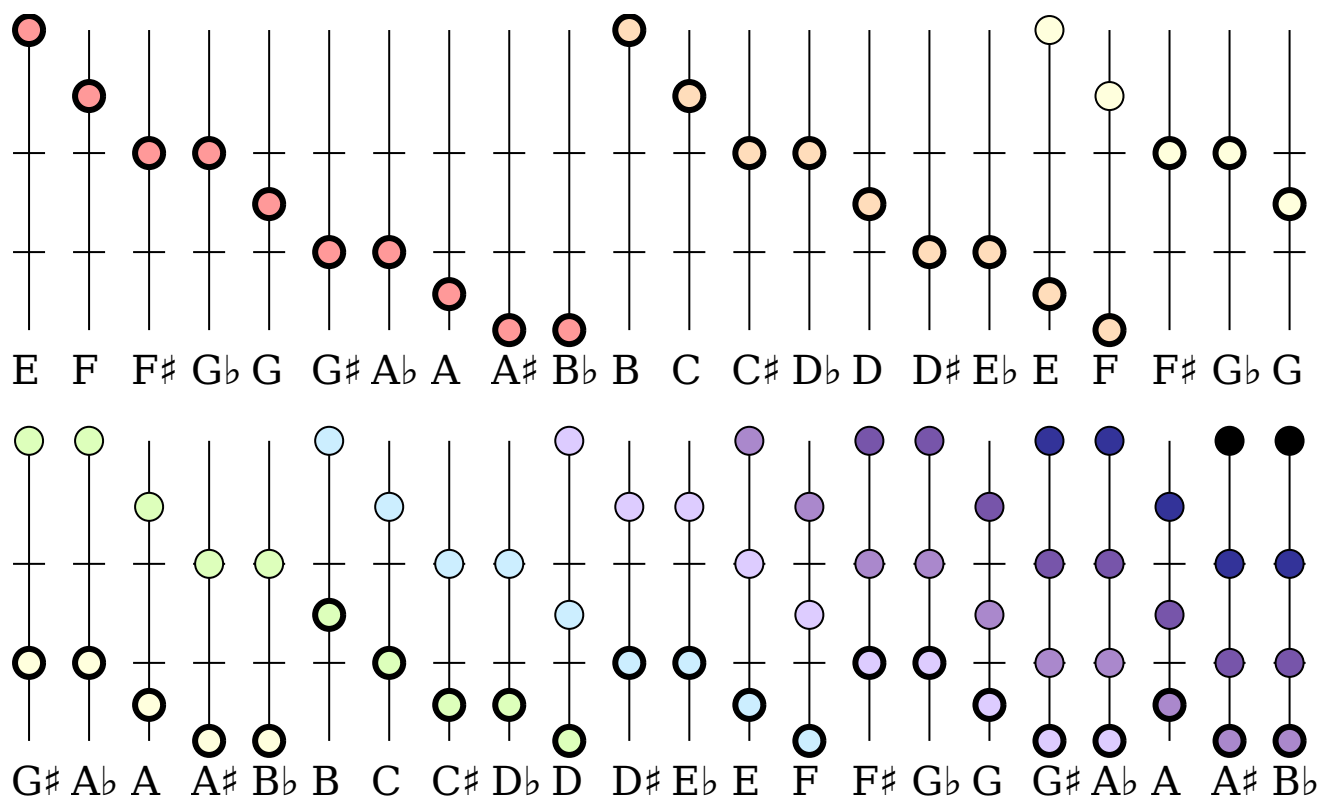

Gamme chromatique ascendante

Voici 31 notes.

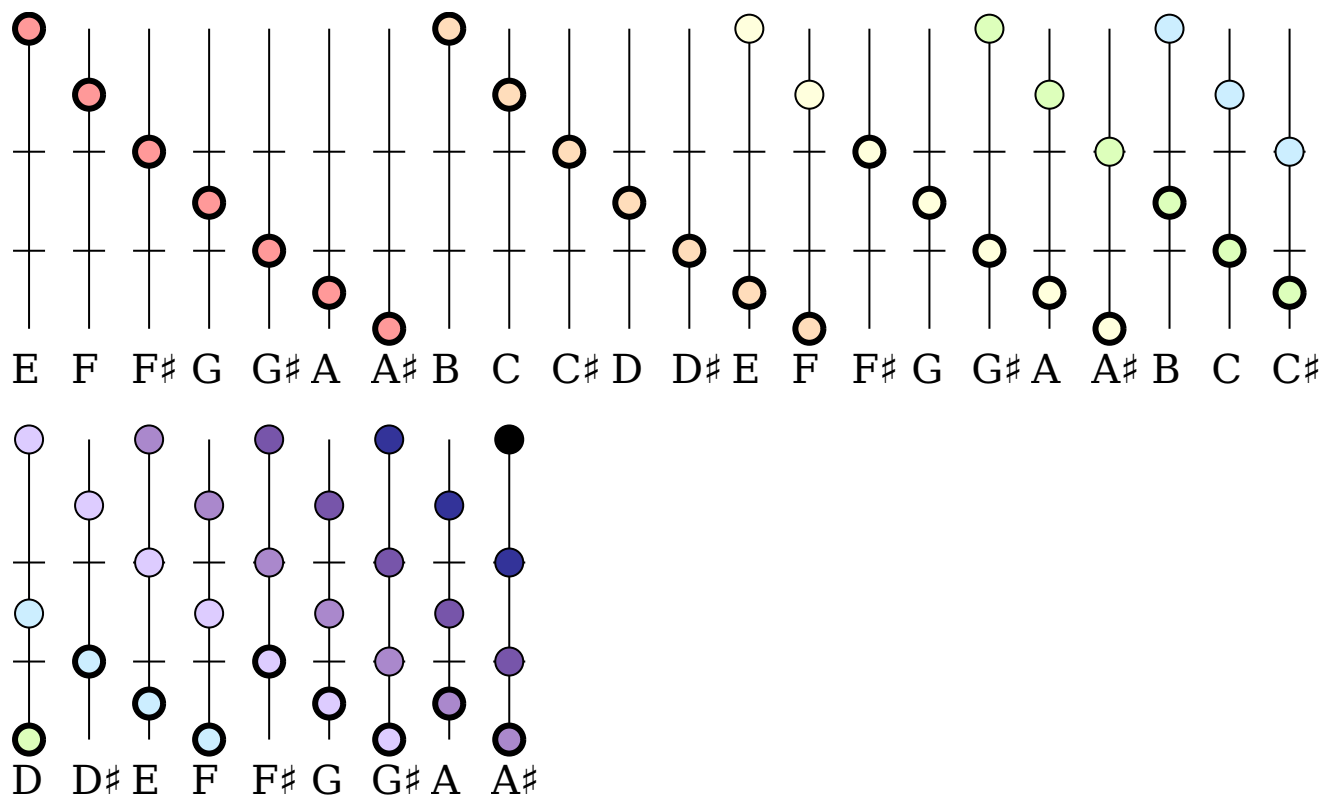

Gamme chromatique descendante

Voici 31 notes.

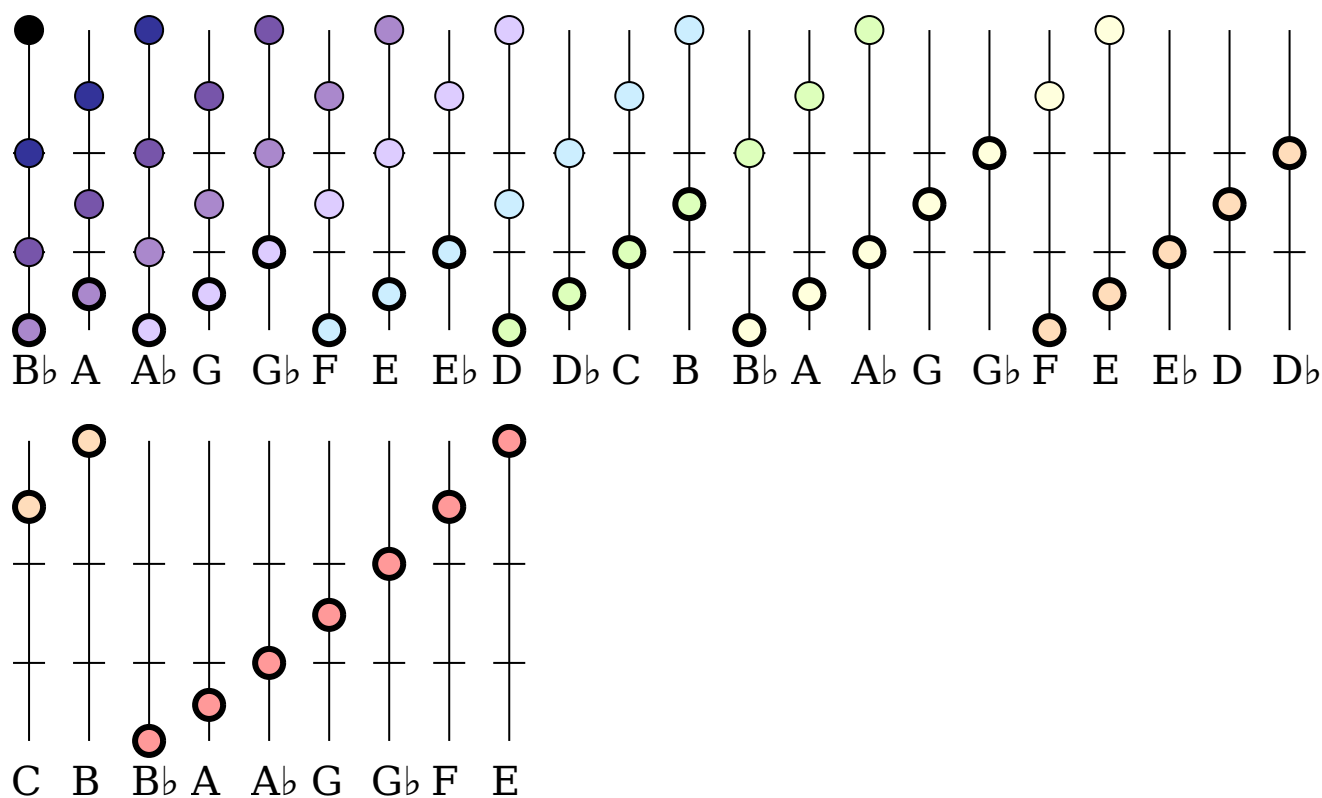

Notes n'ayant qu'une position

Il y en a 20, réparties sur 14 positions.

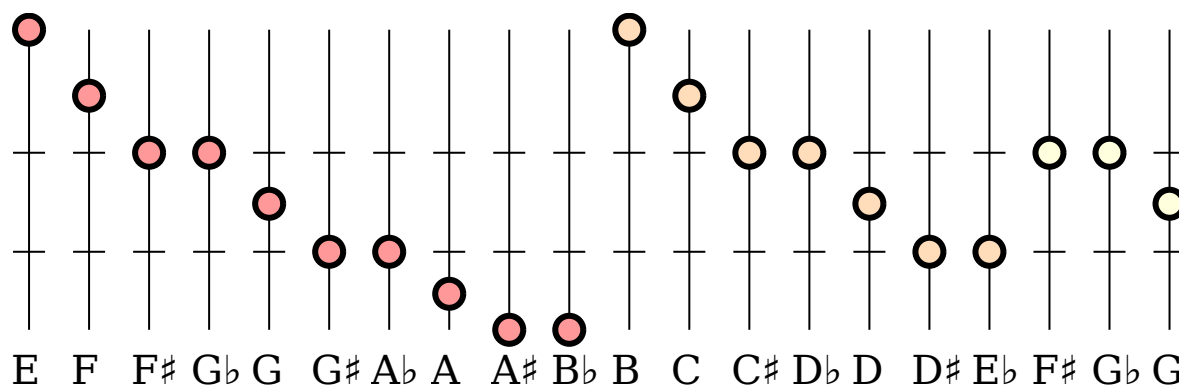

Notes ayant deux positions

Il y en a 13, réparties sur 9 positions.

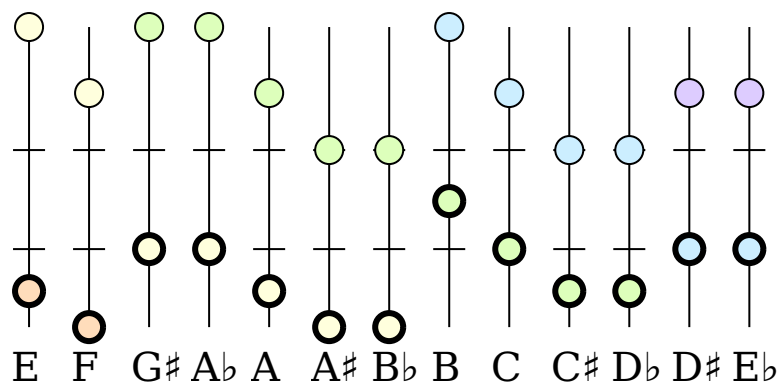

Notes ayant trois positions

Il y en a 7, réparties sur 6 positions.

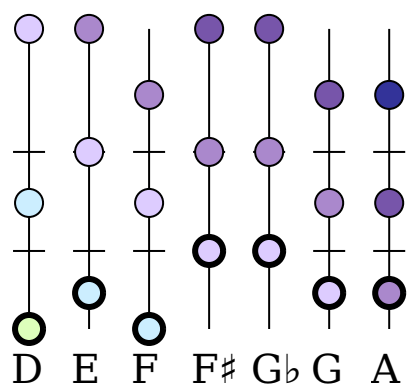

Notes ayant quatre positions

Il y en a 4, réparties sur 2 positions.

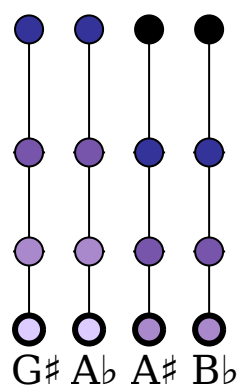

Gammes majeures

C

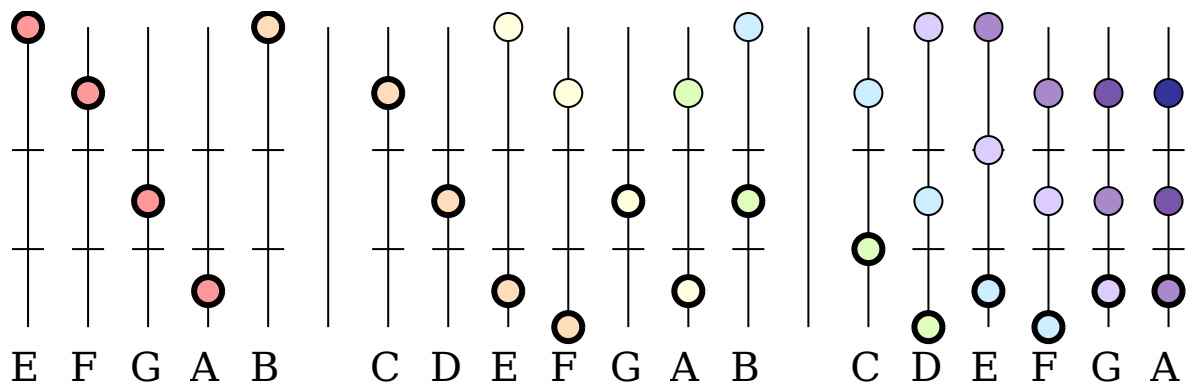

D_b

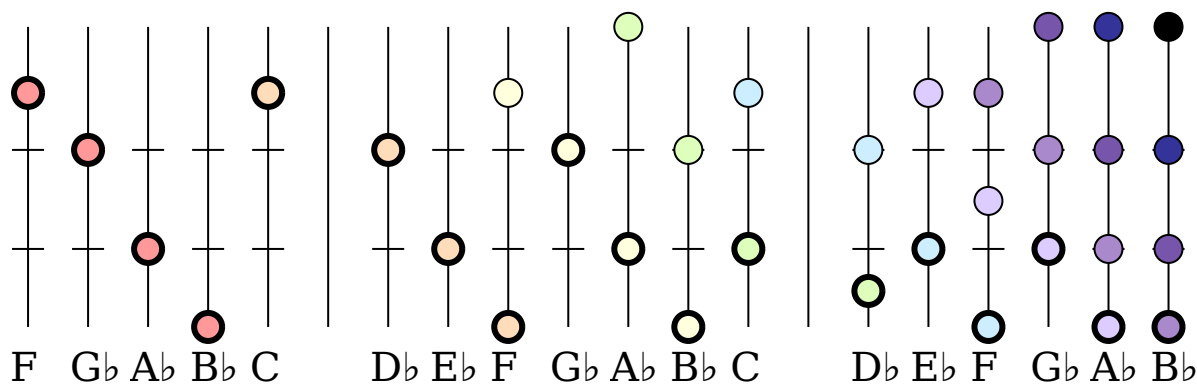

D

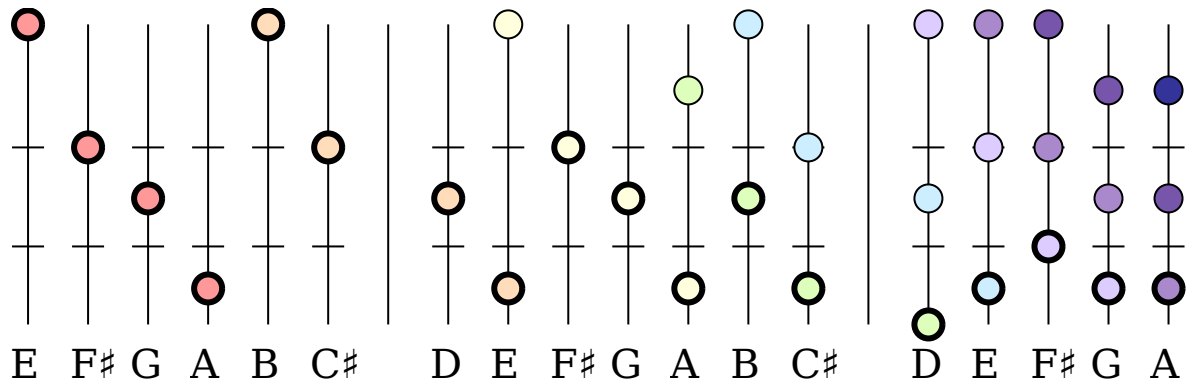

E_b

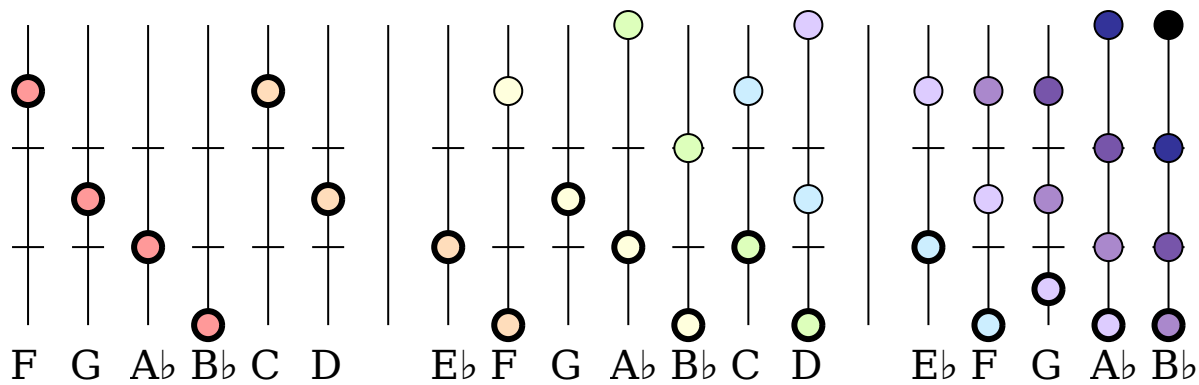

E

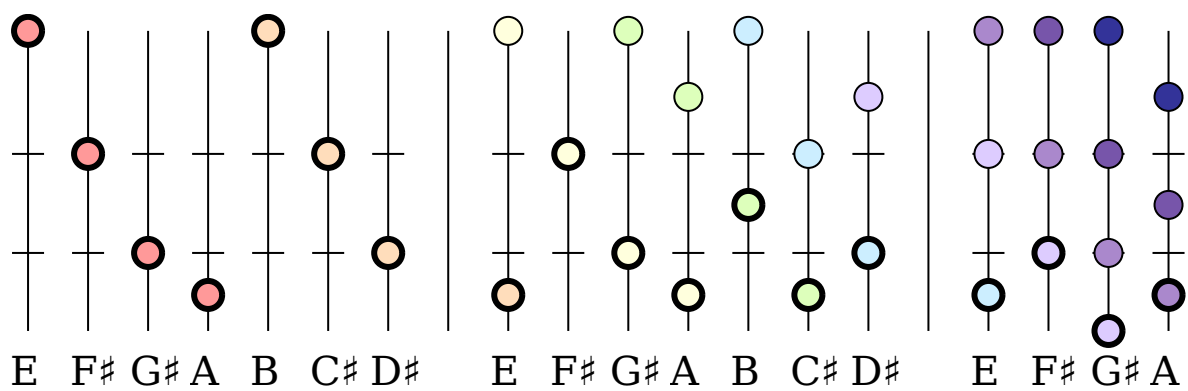

F

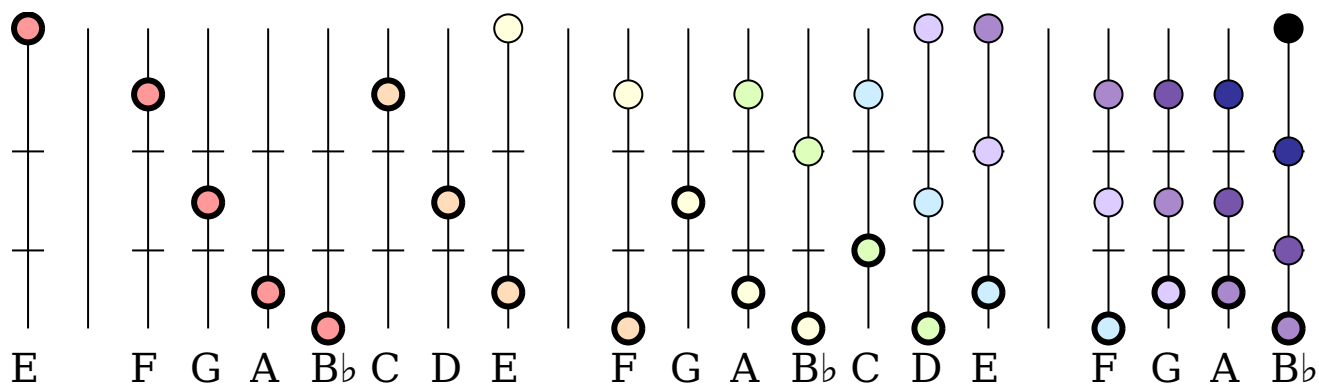

F#

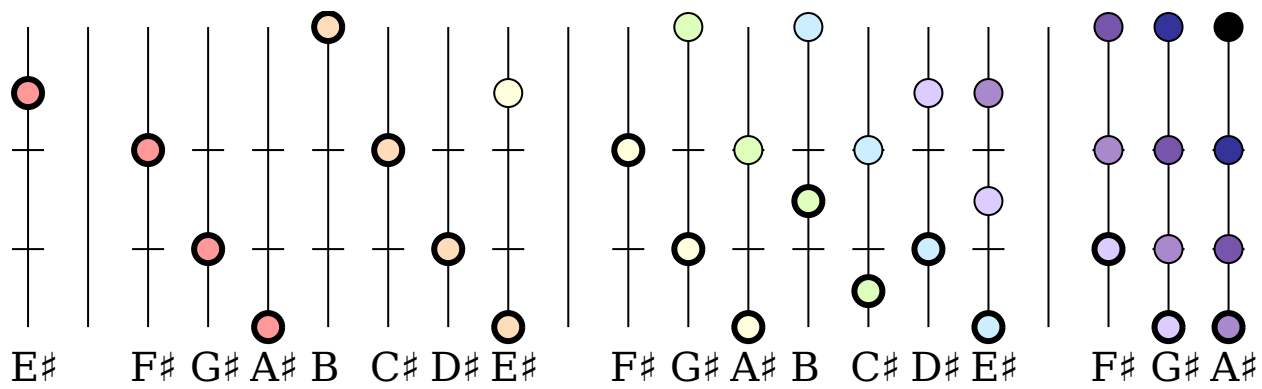

G^b

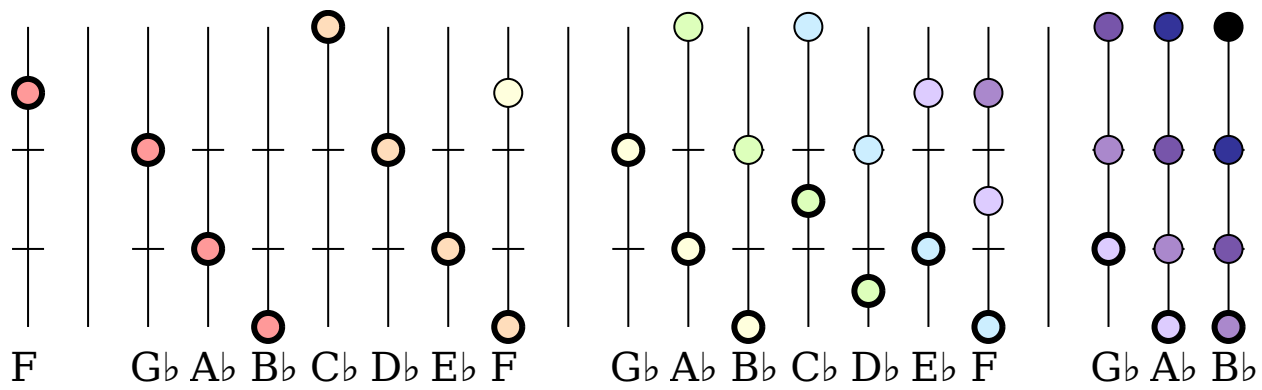

G

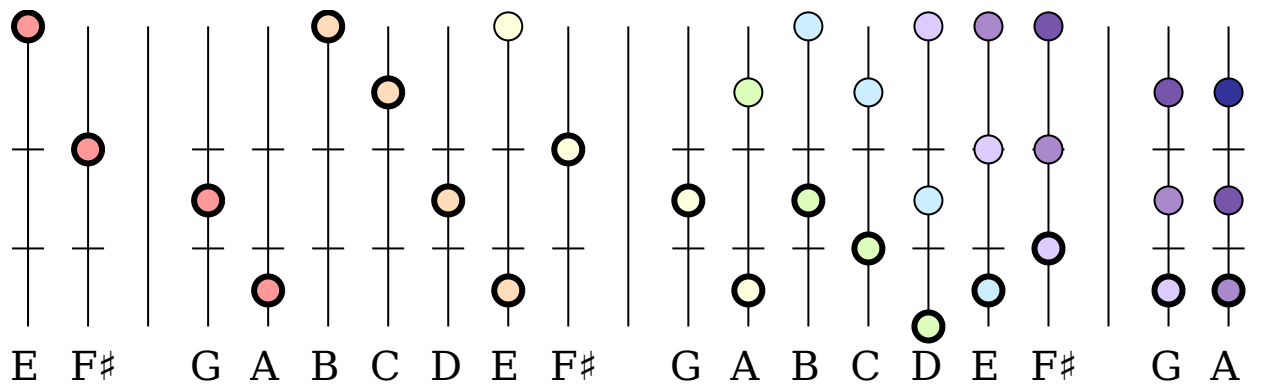

A^b

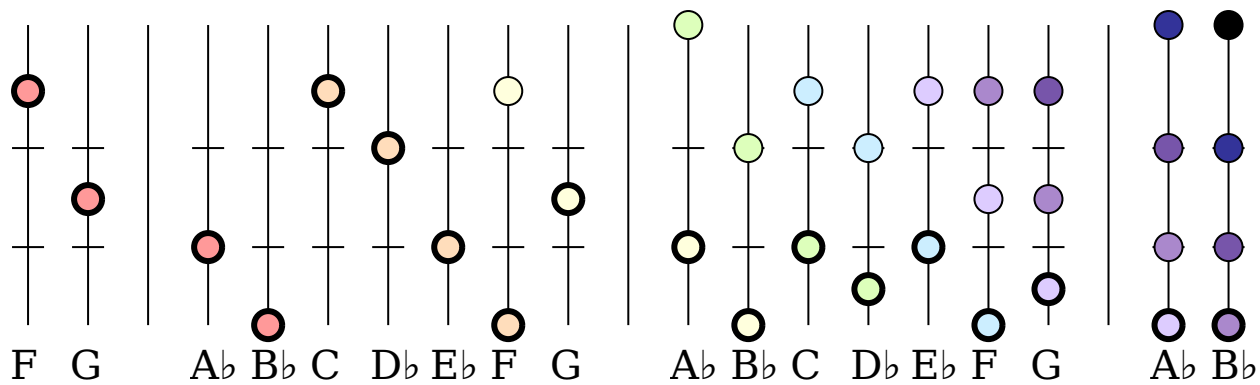

A

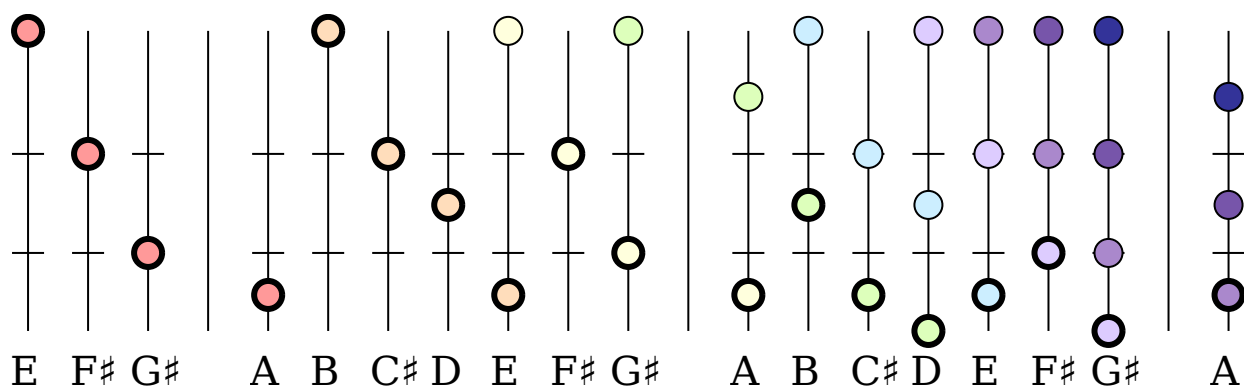

B_b

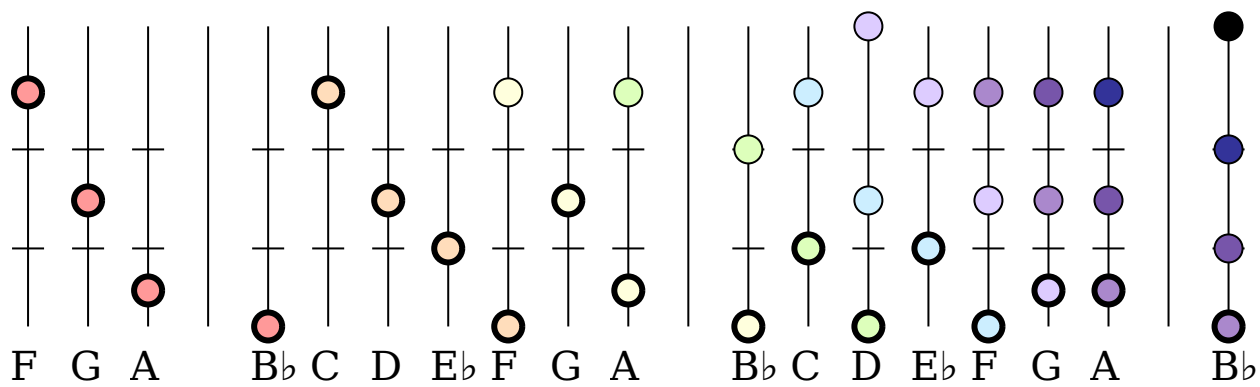

B

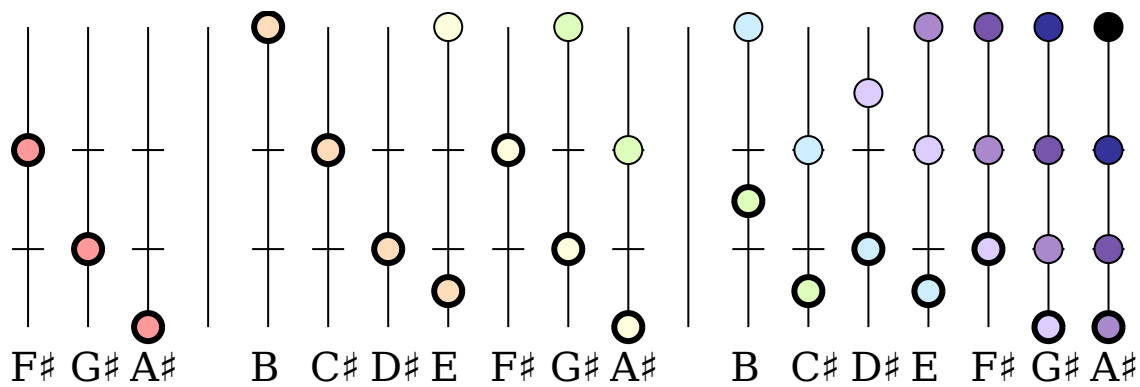

Gammes pentatoniques majeures

C

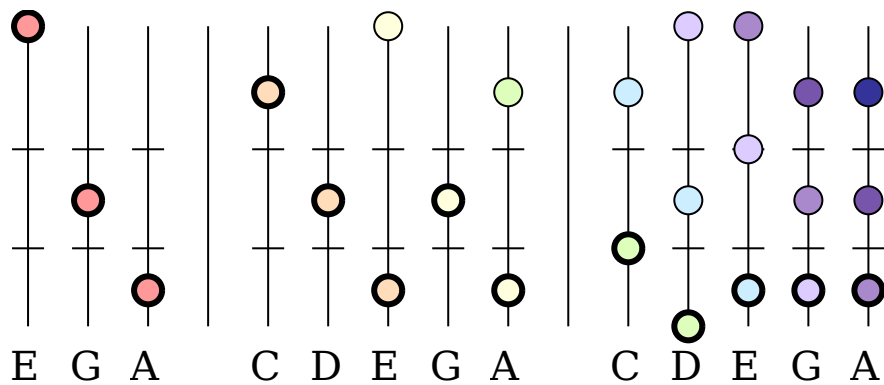

D^b

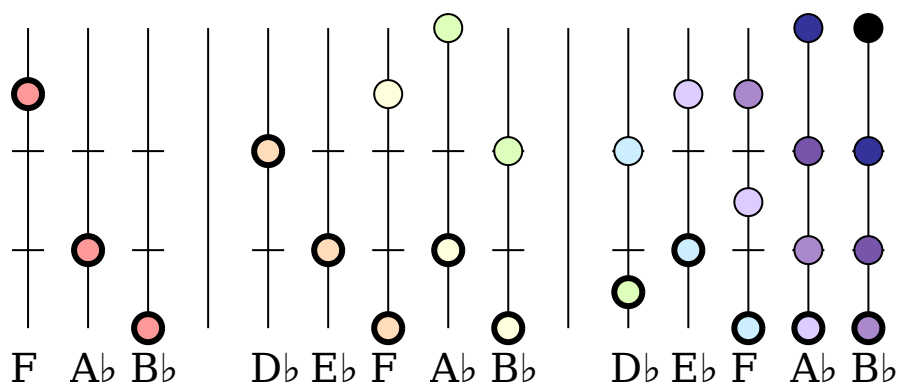

D

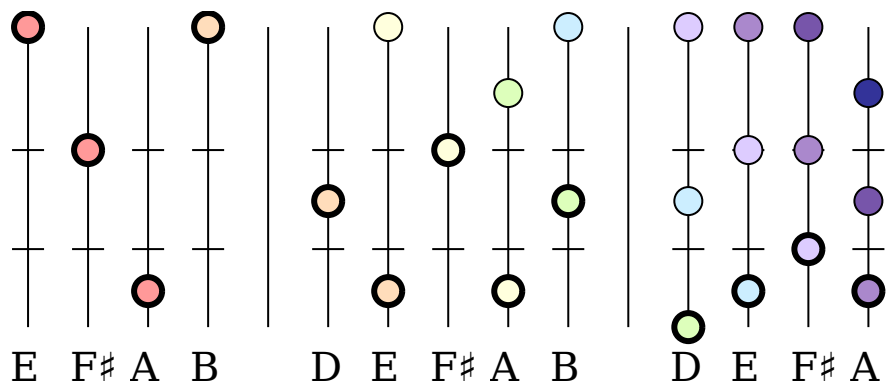

E_b

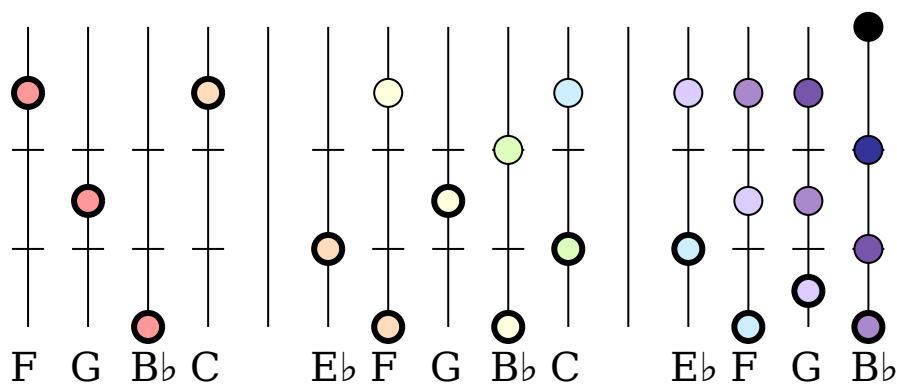

E

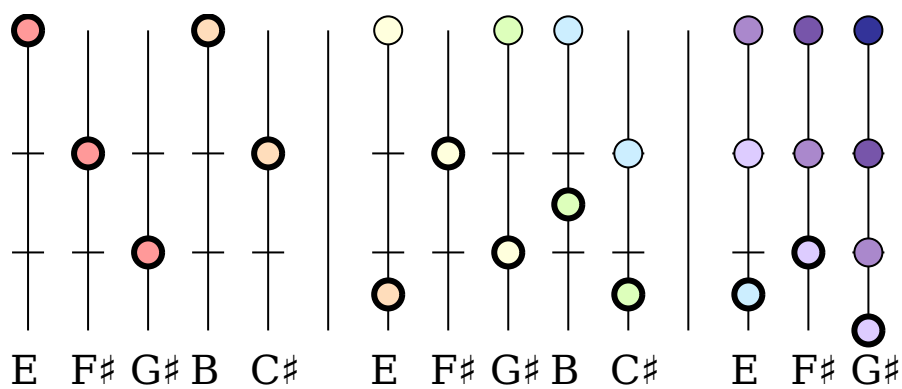

F

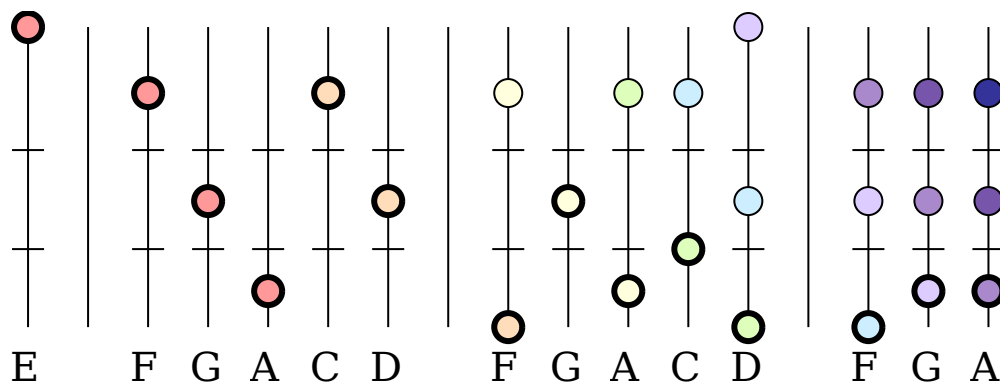

F#

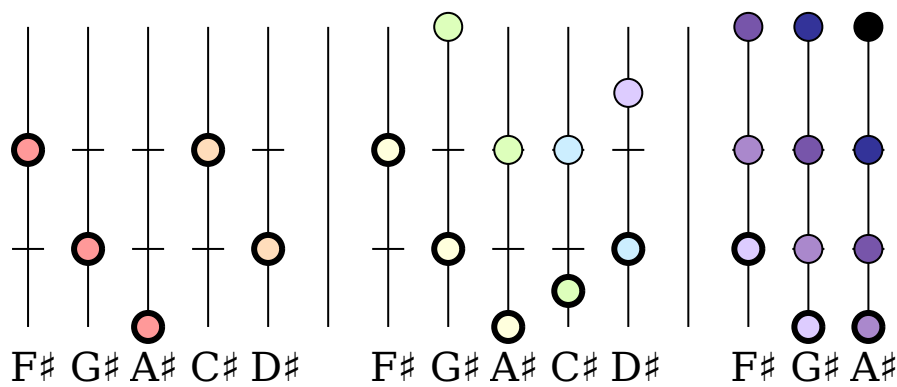

Gb

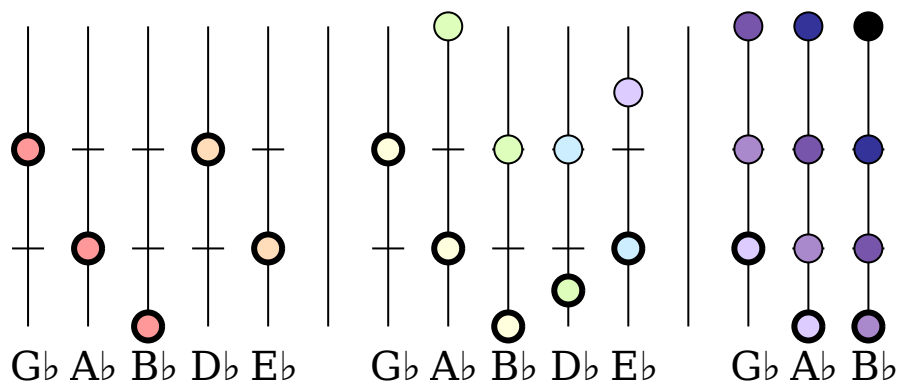

G

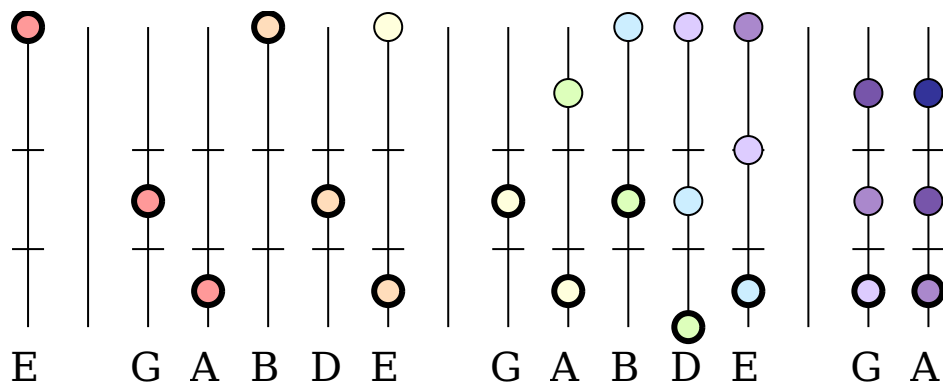

A^b

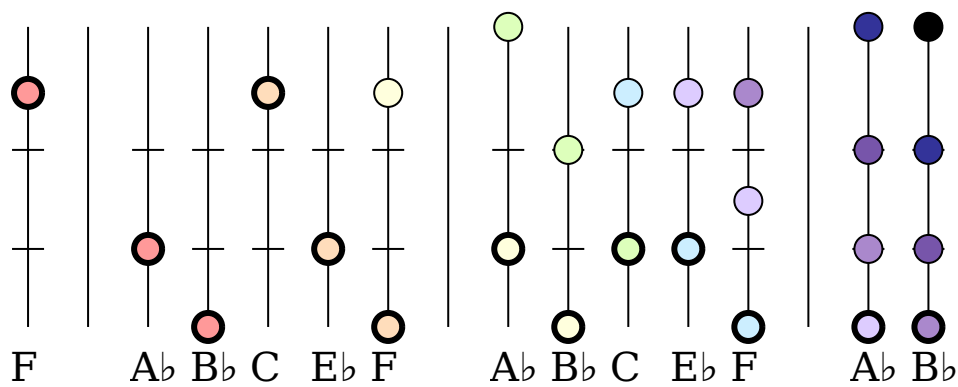

A

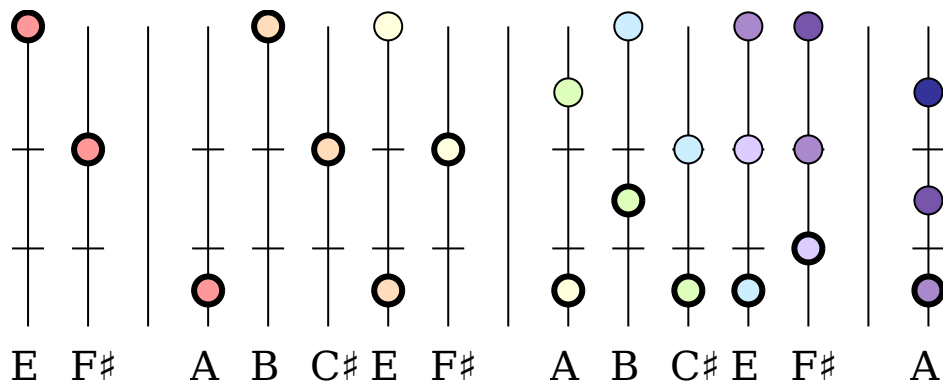

B^b

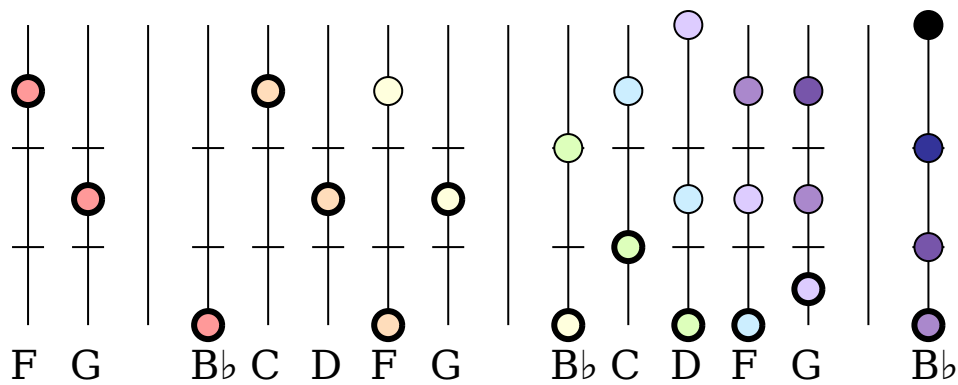

B

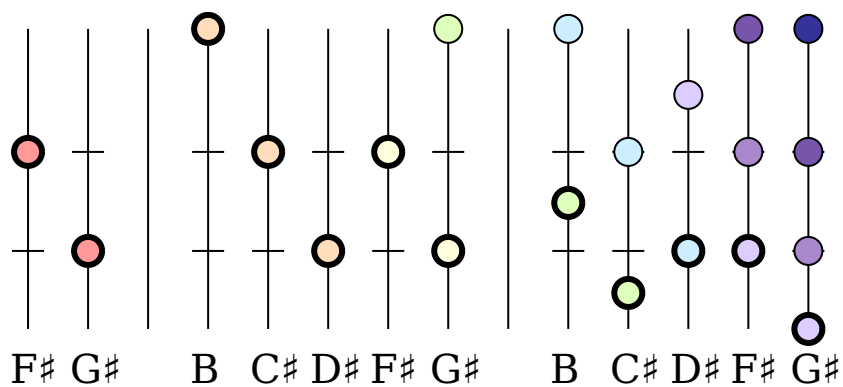

Triades majeures

C

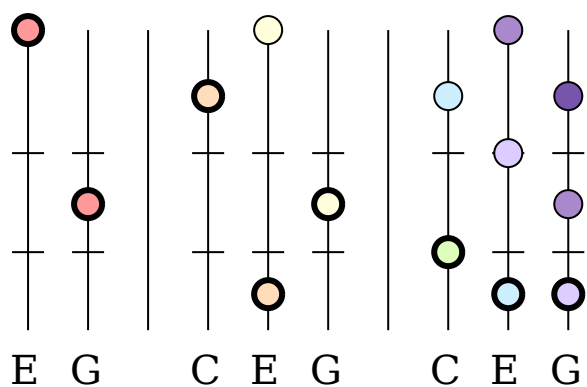

D_b

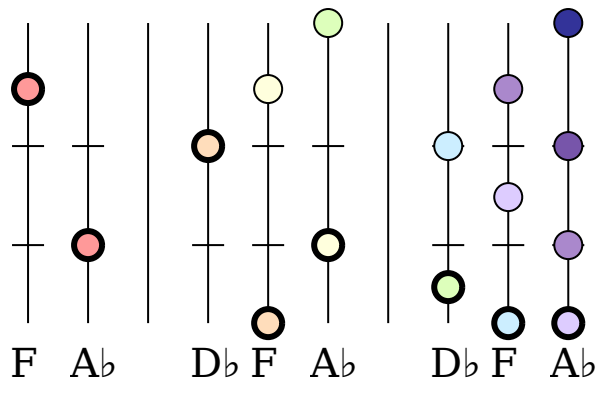

D

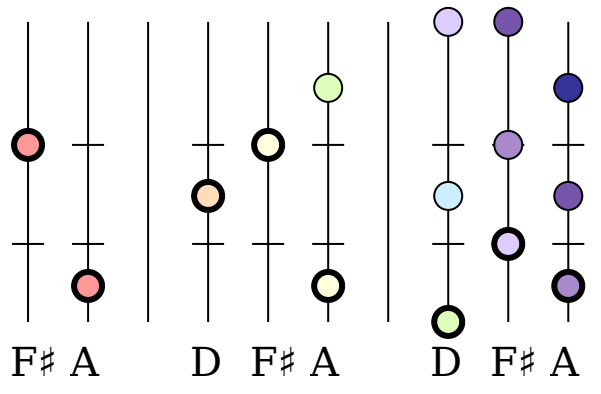

E_b

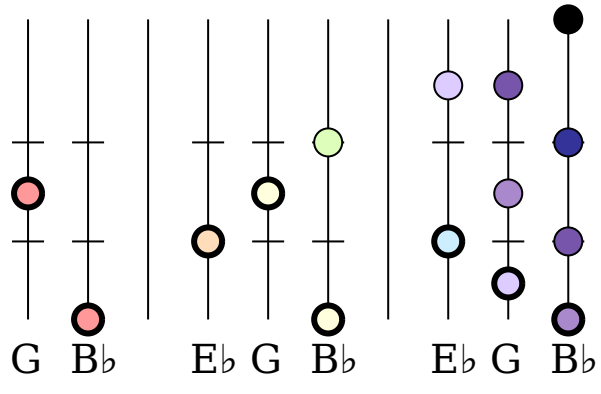

E

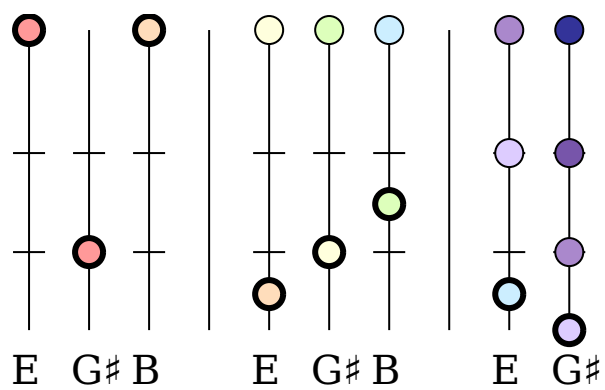
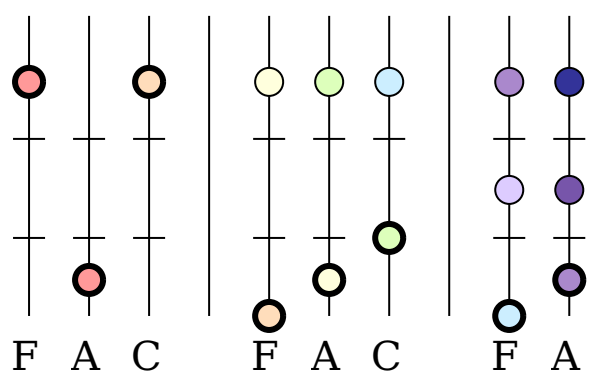
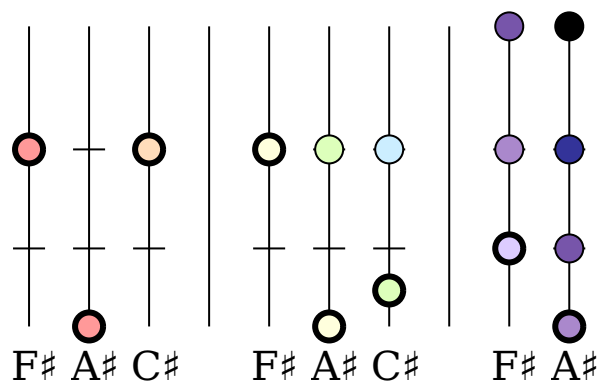
**F****F#****G^b**

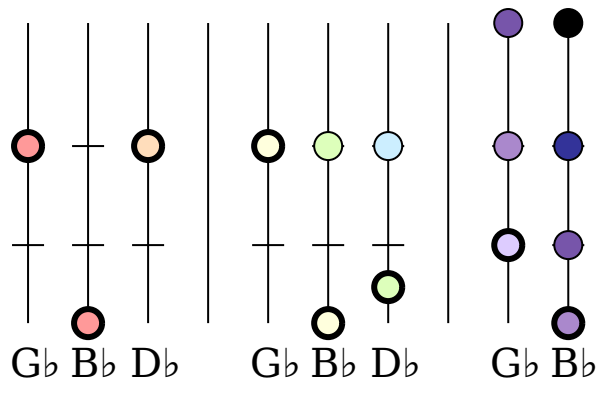

G

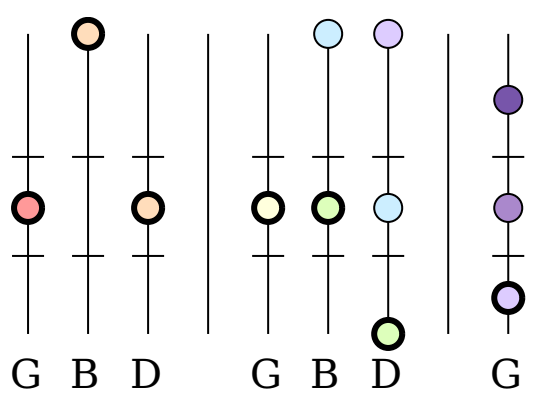

A_b

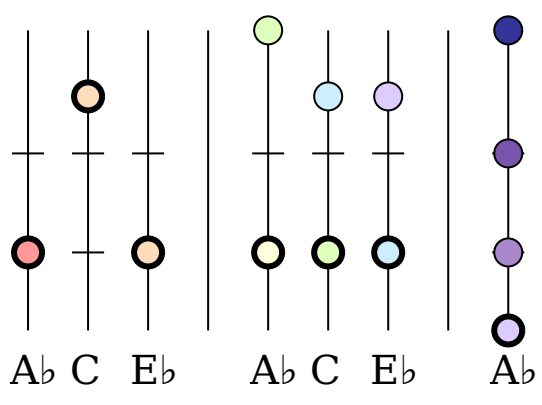

A

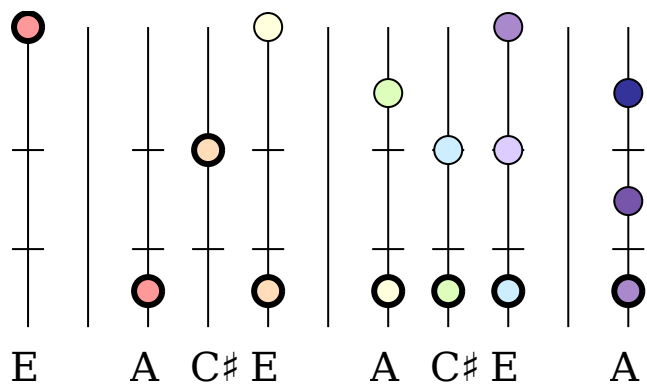

B_b

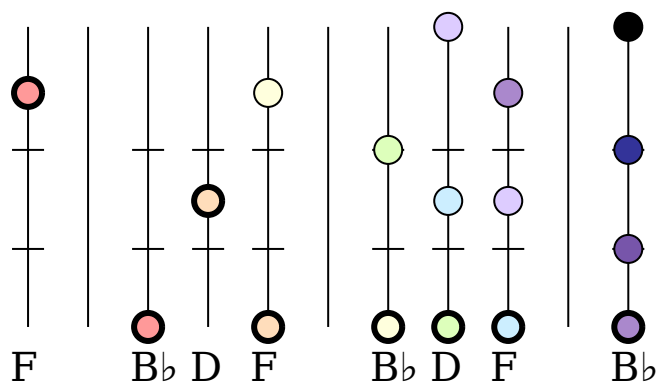

B

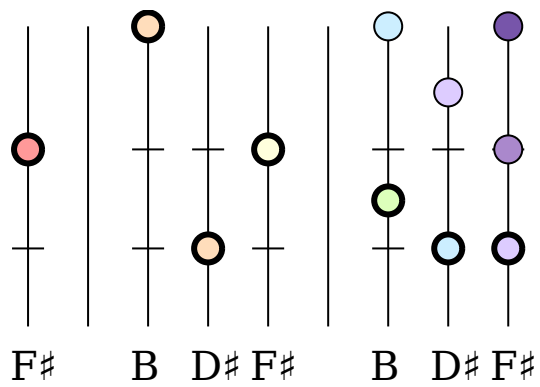

Gammes mineures

C

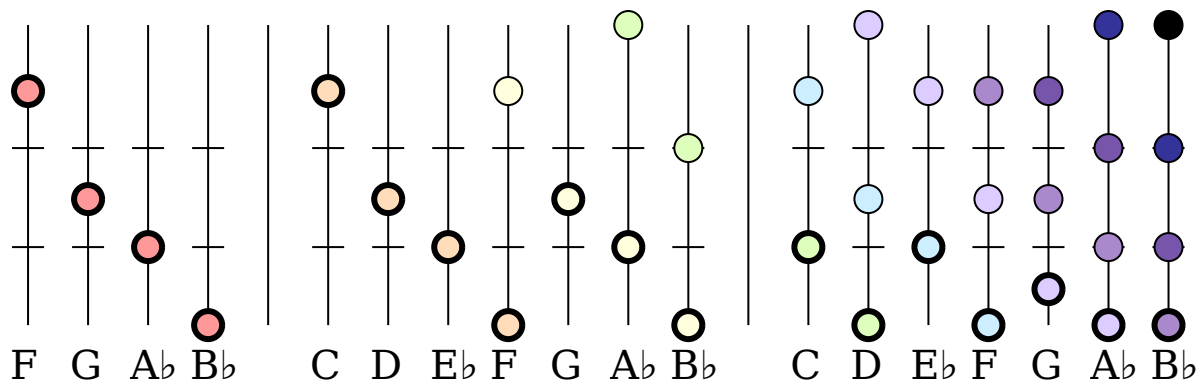

C#

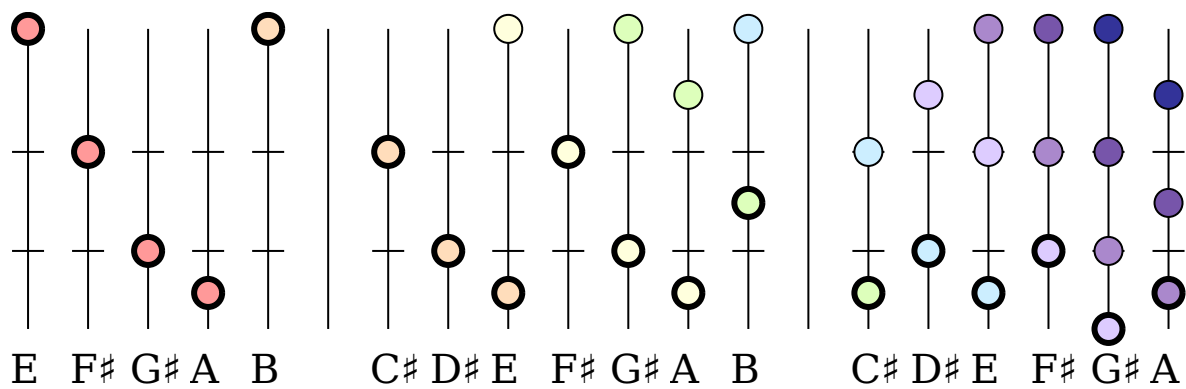

D

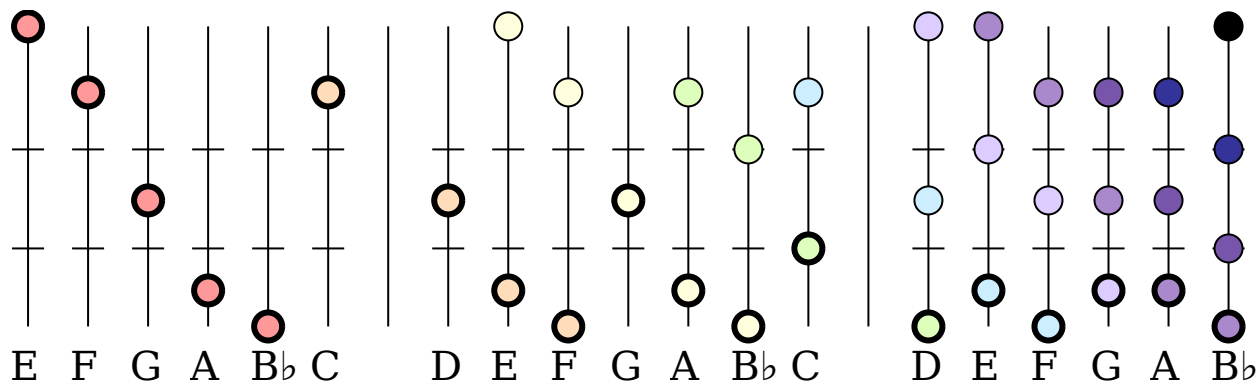

D#

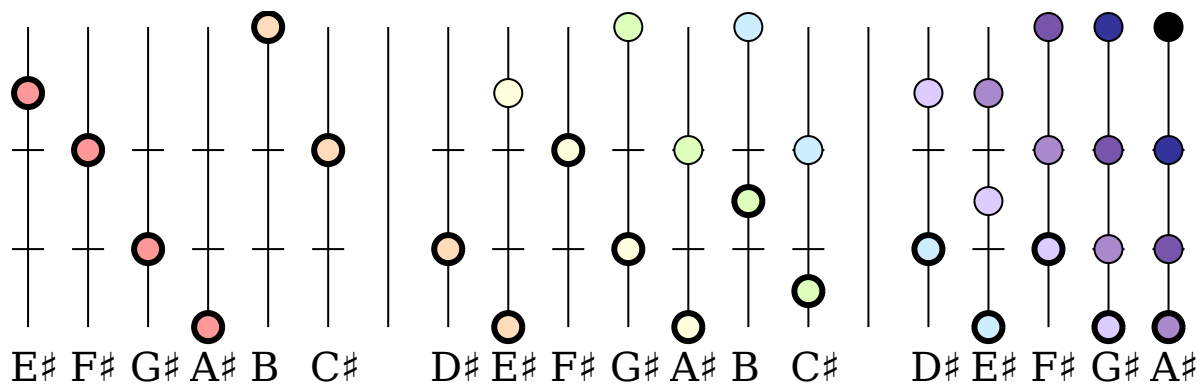

E_b

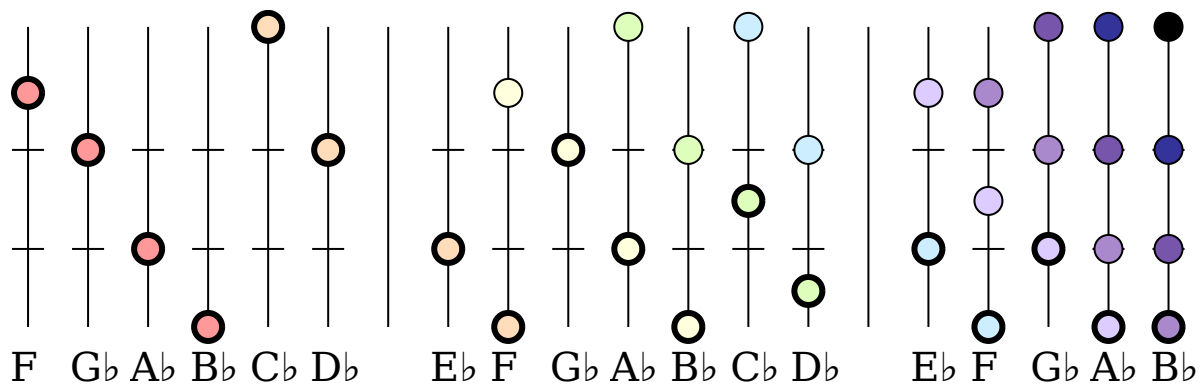

E

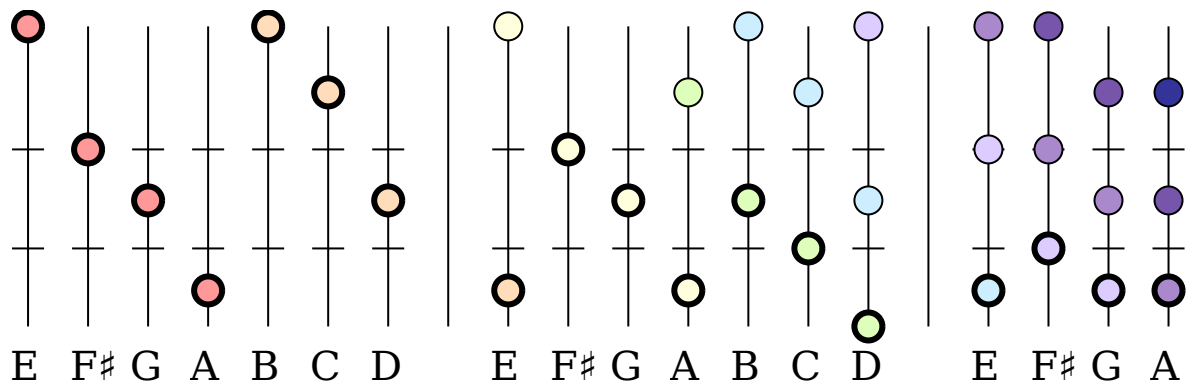

F

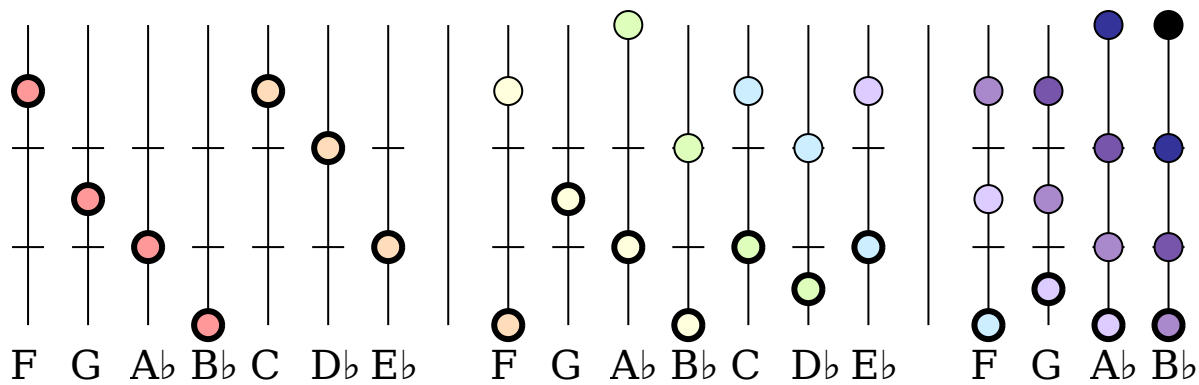

F#

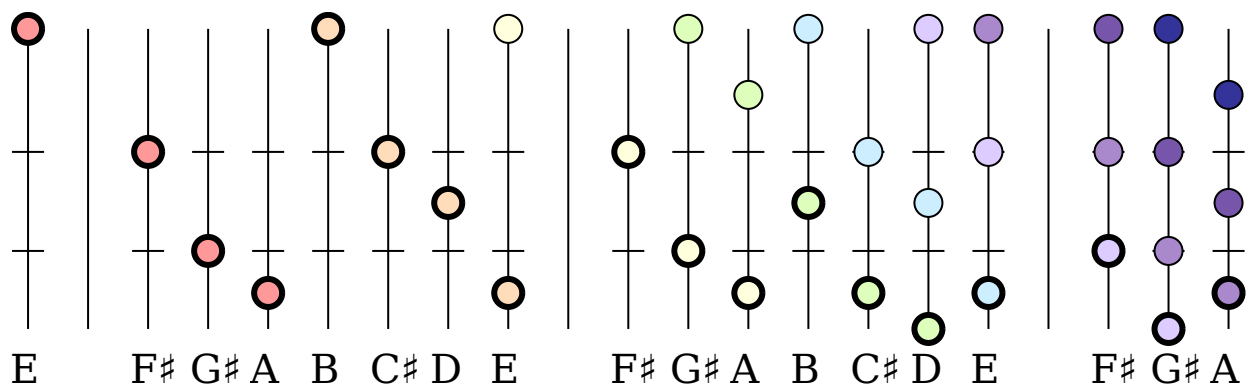

G

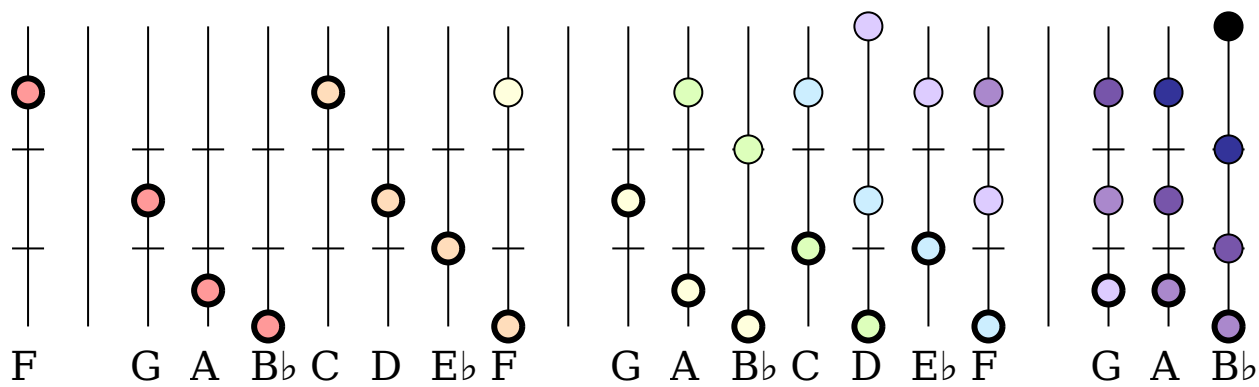

G#

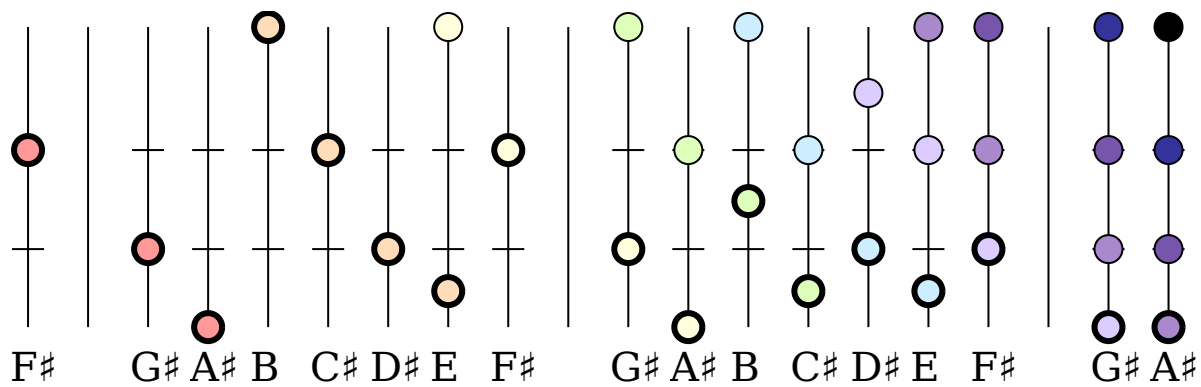

A

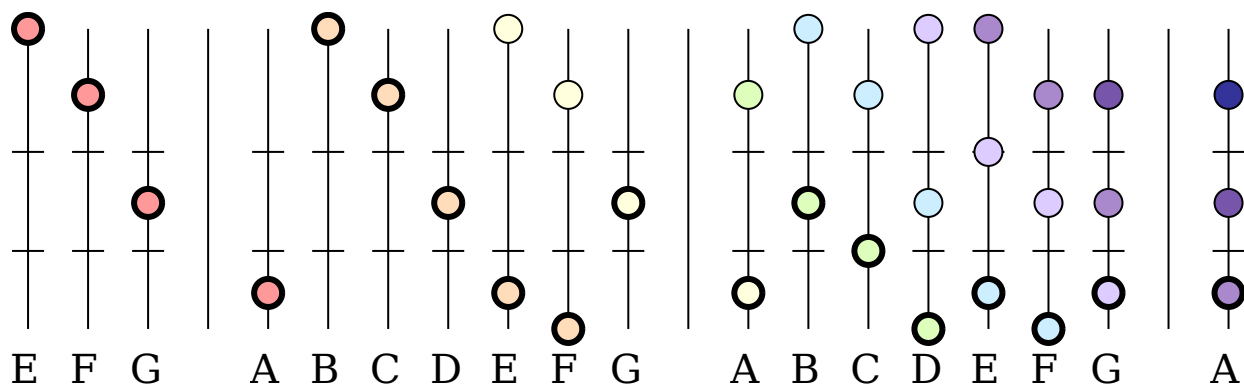

B_b

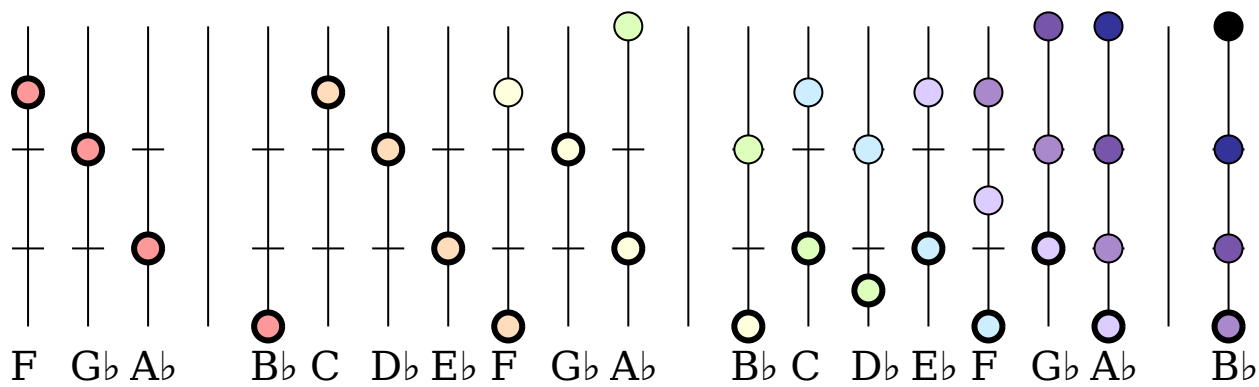

B

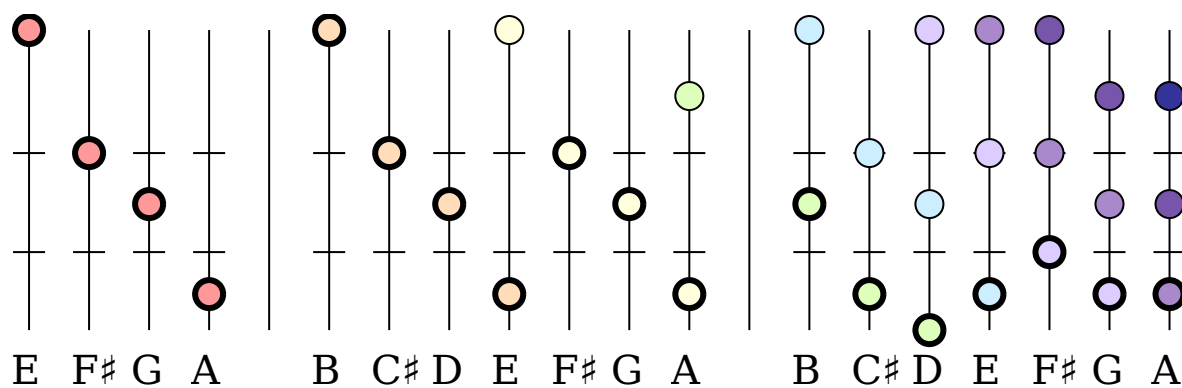

Gammes pentatoniques mineures

C

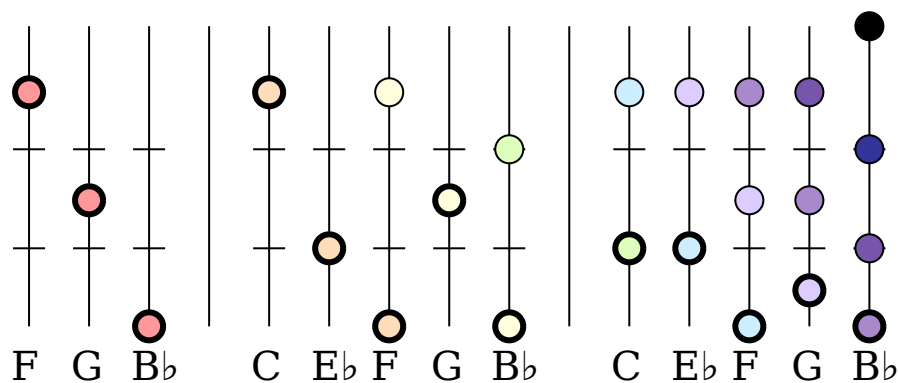

C#

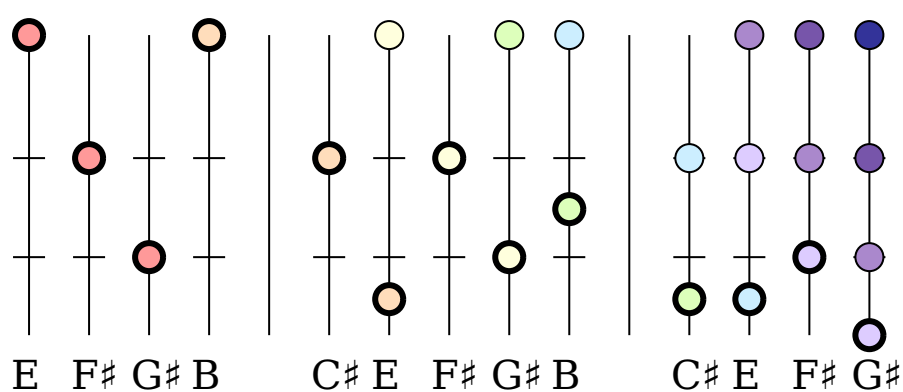

D

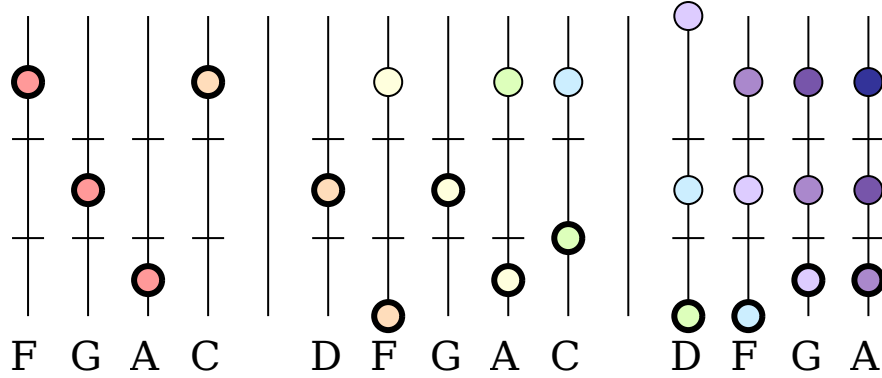

D#

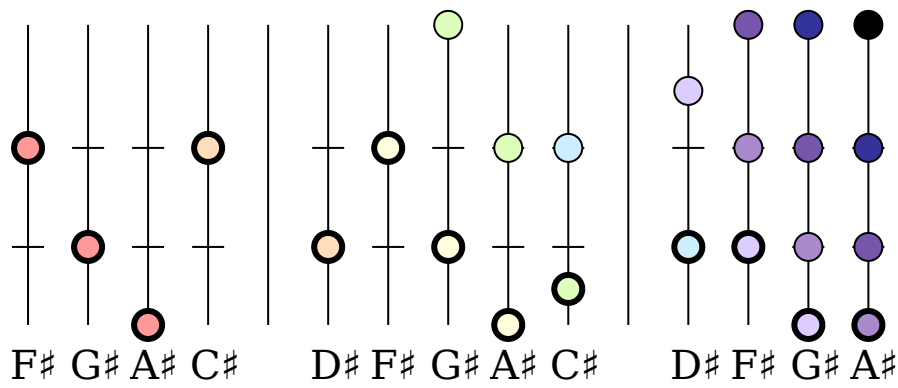

E_b

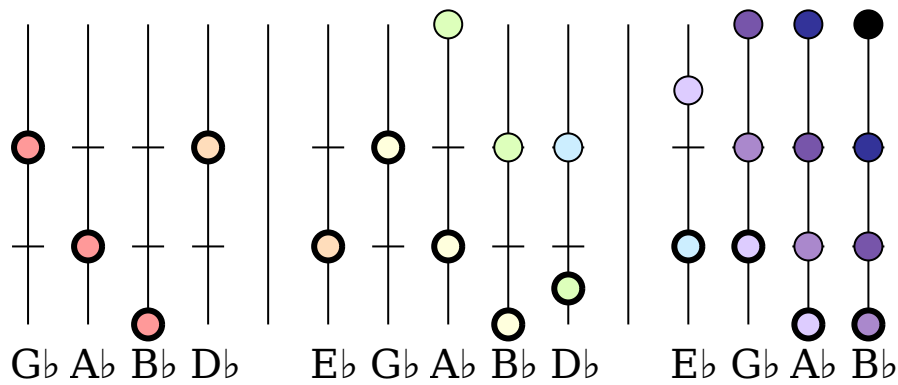

E

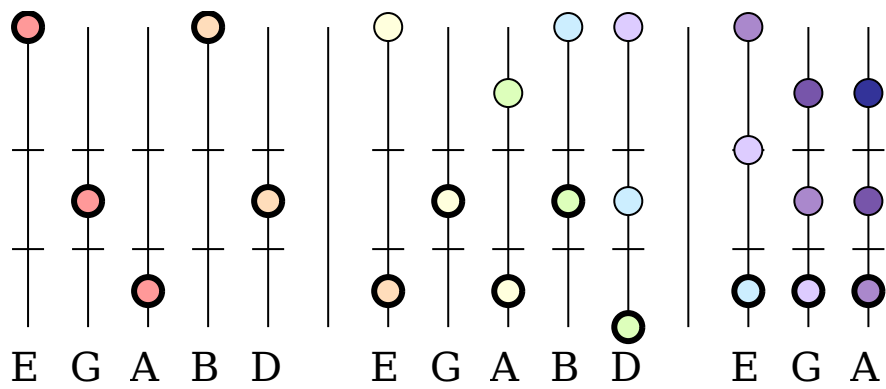

F

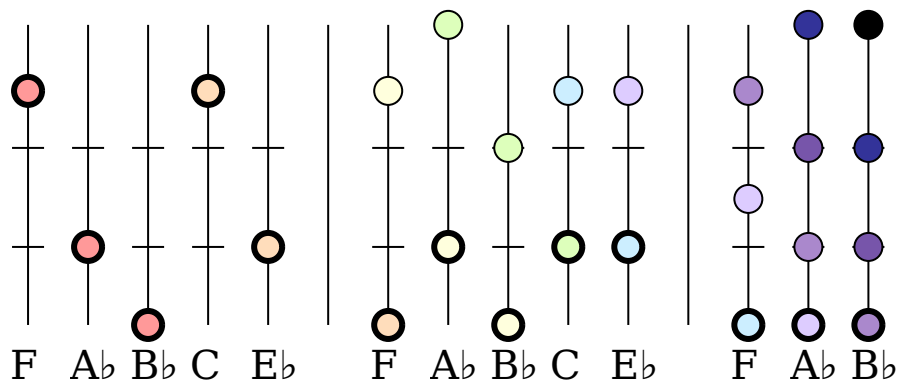

F#

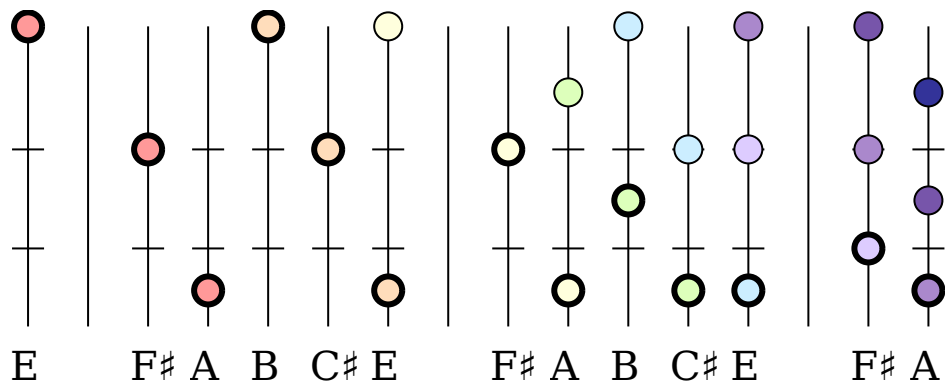

G

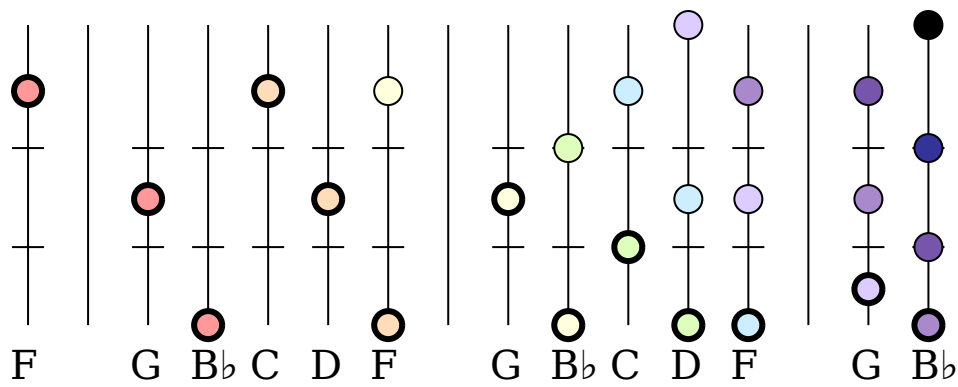

G#

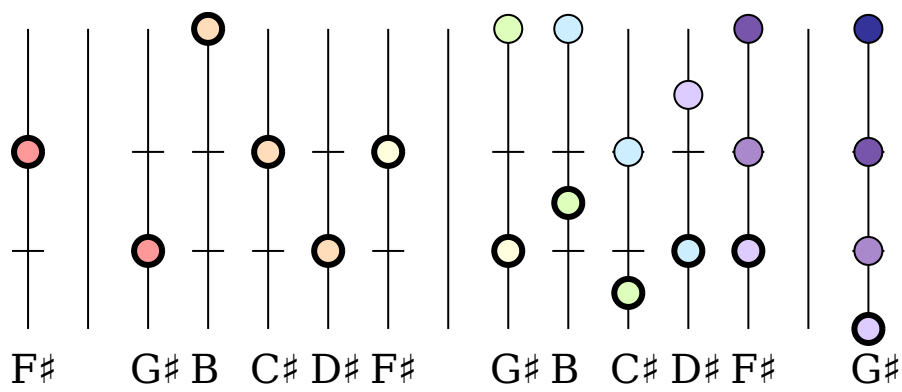

A

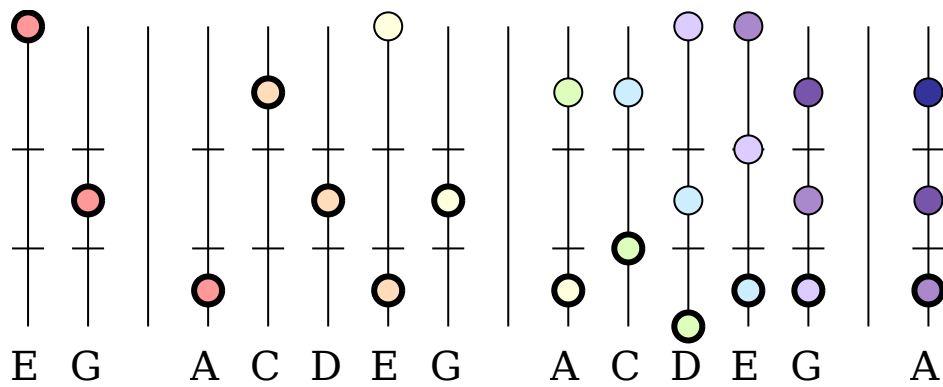

B_b

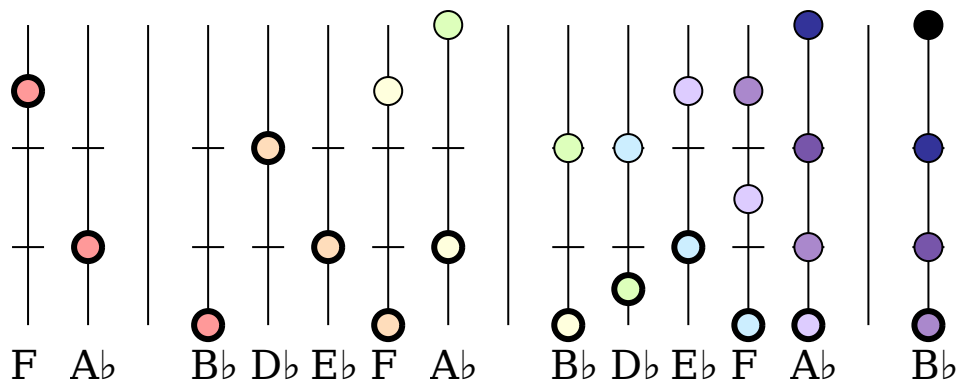

B

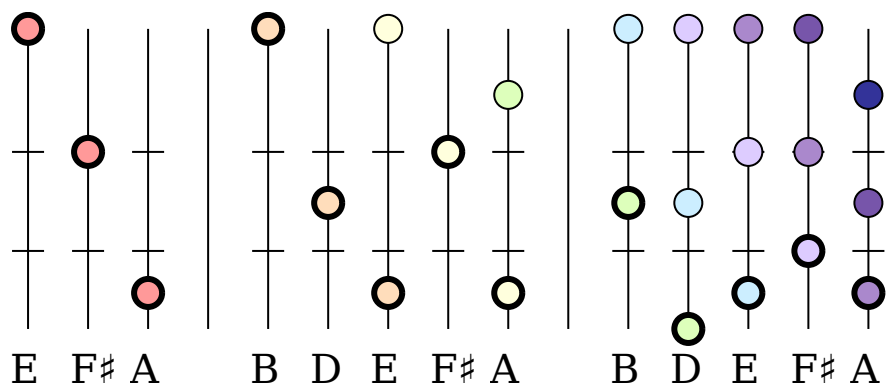

Triades mineures

C

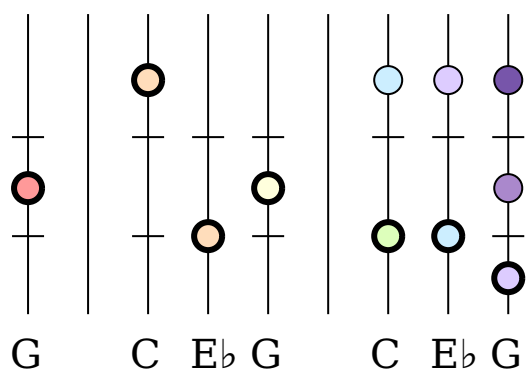

C[#]

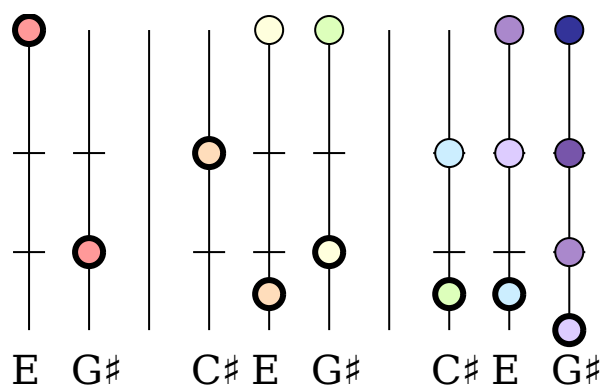
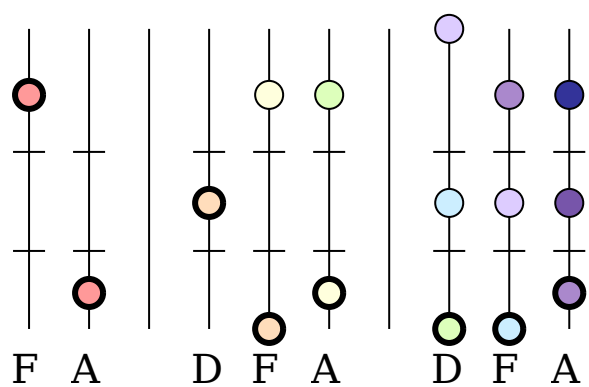
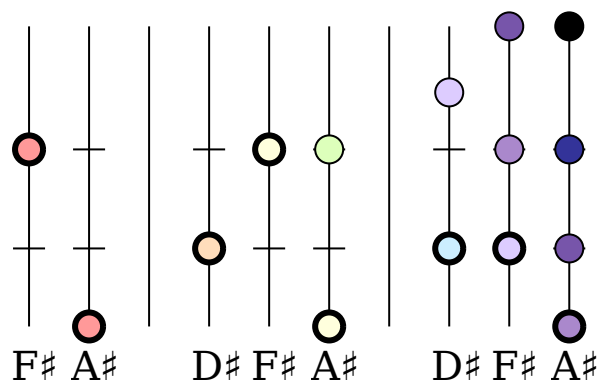
**D****D#****E_b**

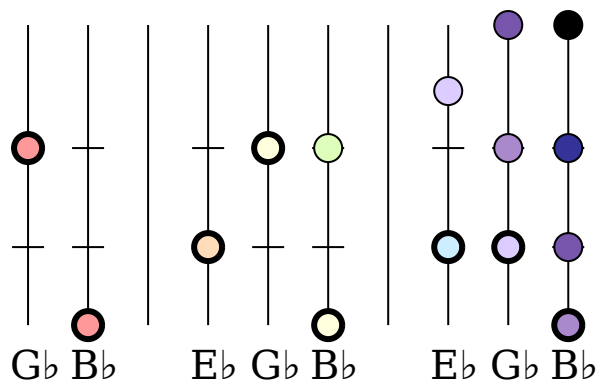

E

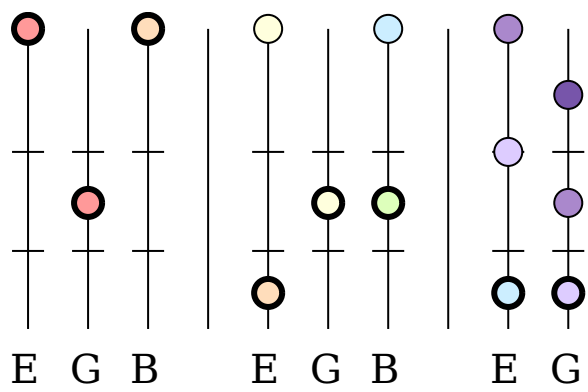

F

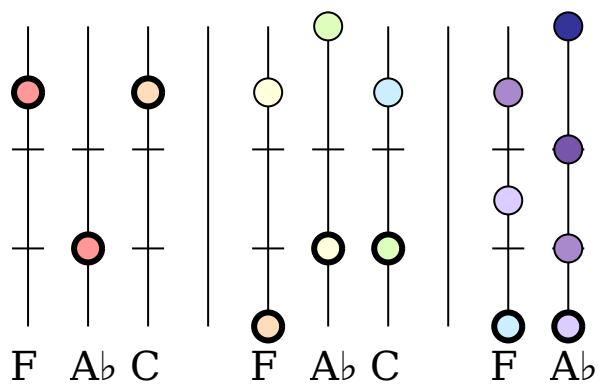

F#

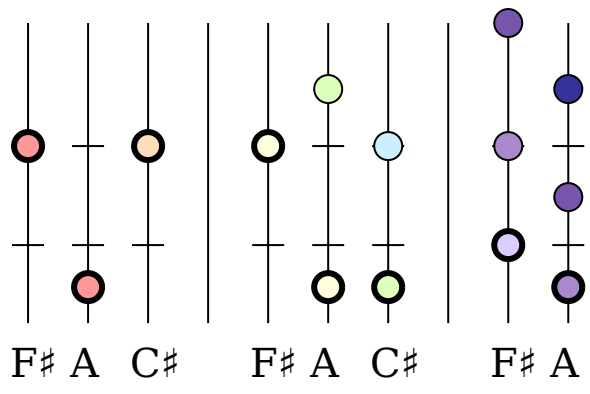

G

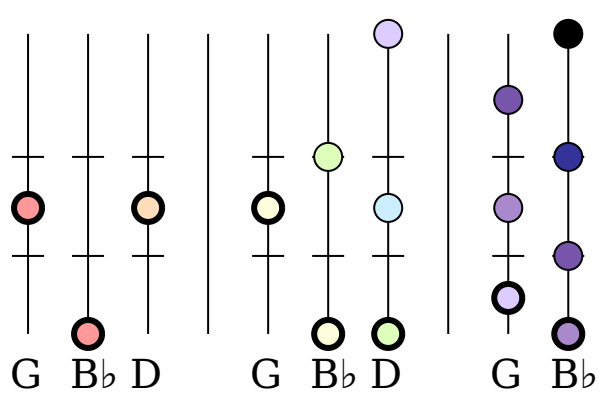

G#

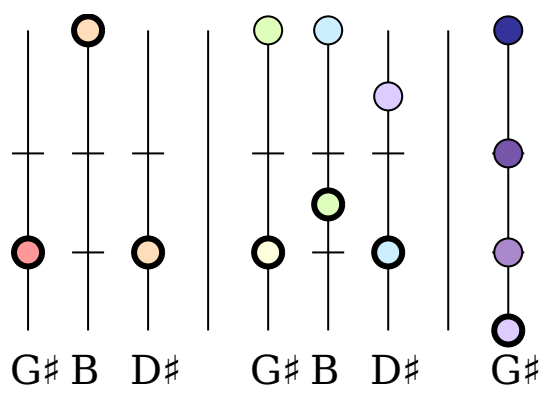

A

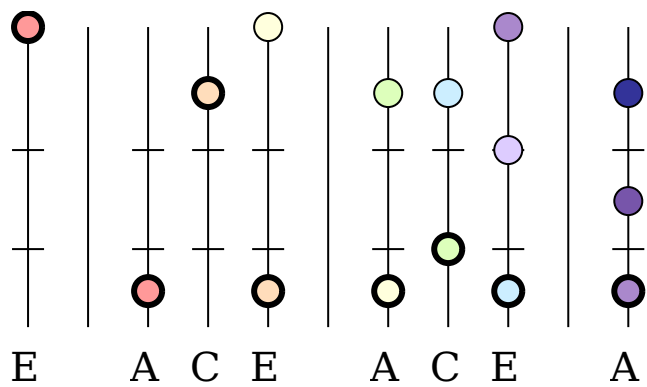

B_b

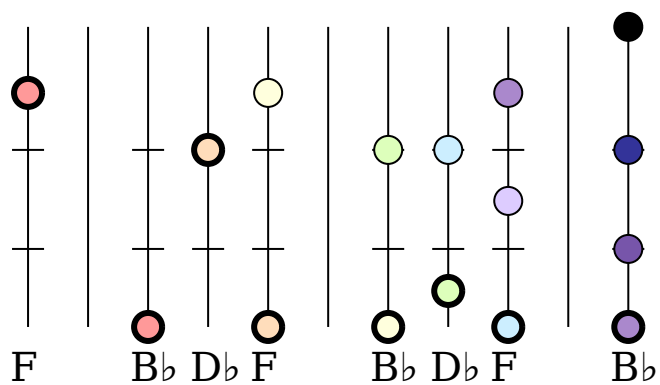

B

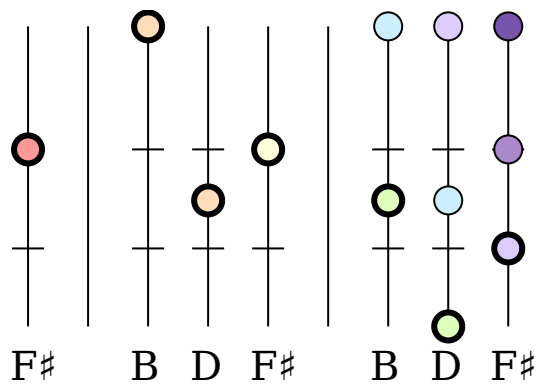

Ruses

Do, Ré, Mi

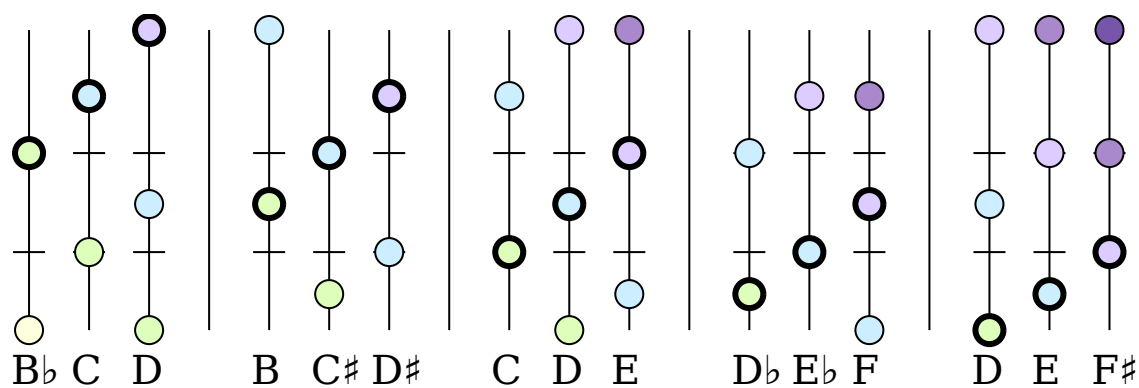

Si, Do, Ré, Mi, Fa

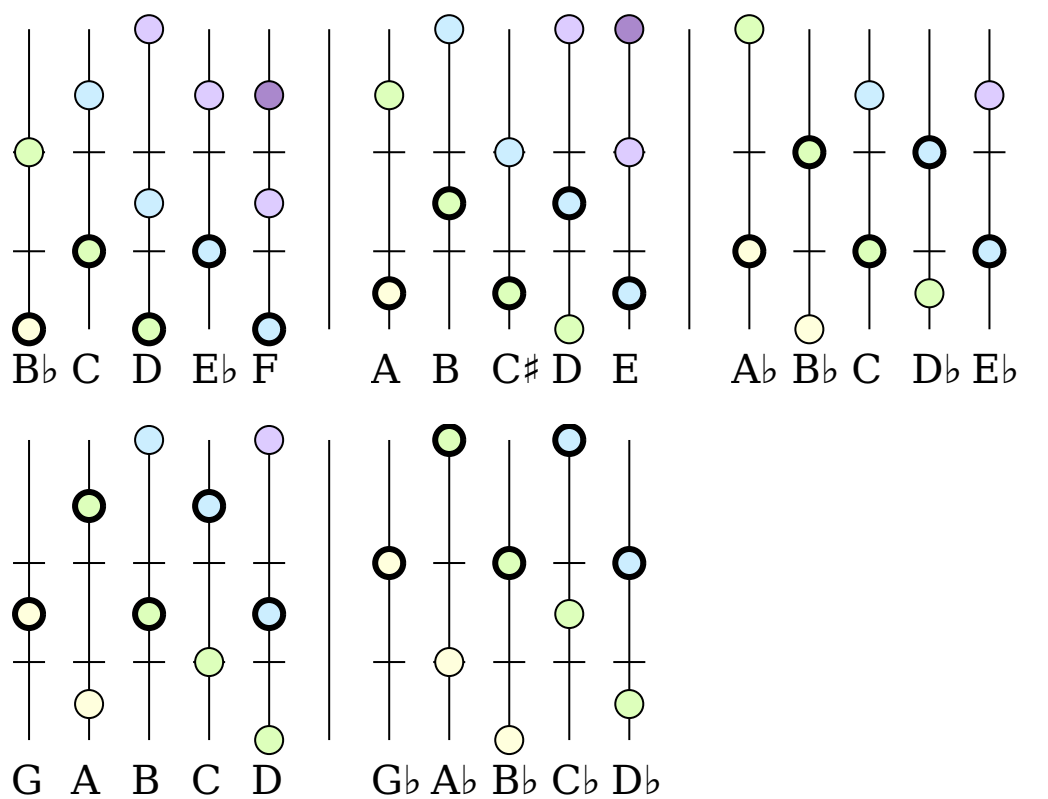

Fa, La, Do, Fa

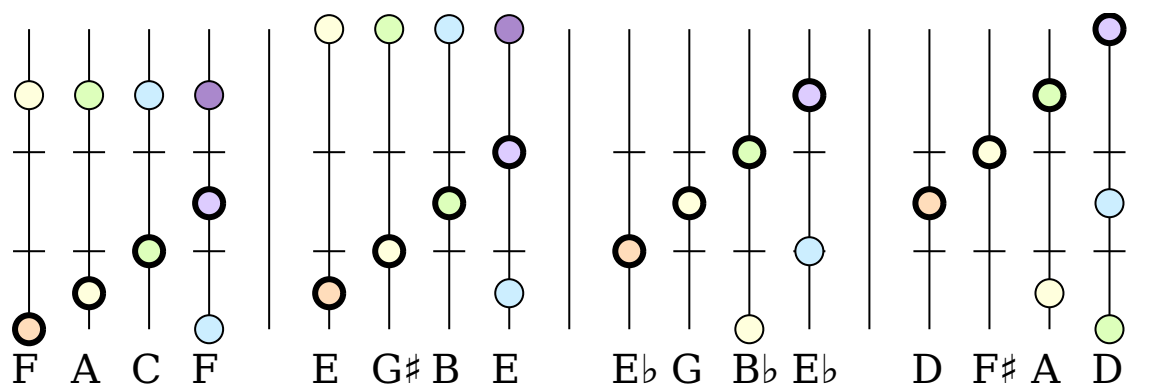

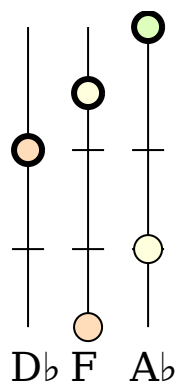

Penta mineure

$b7$ 1 $b3$ 4 5 $b7$ 1 $b3$ 4

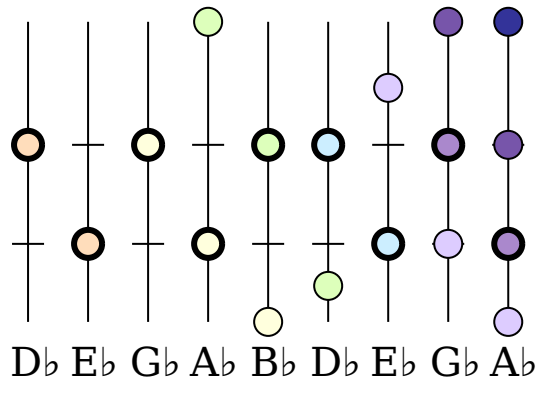
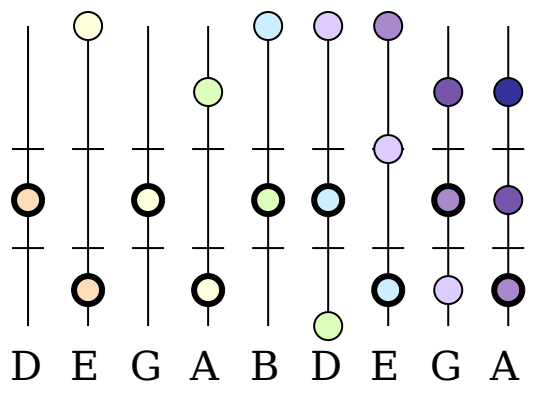
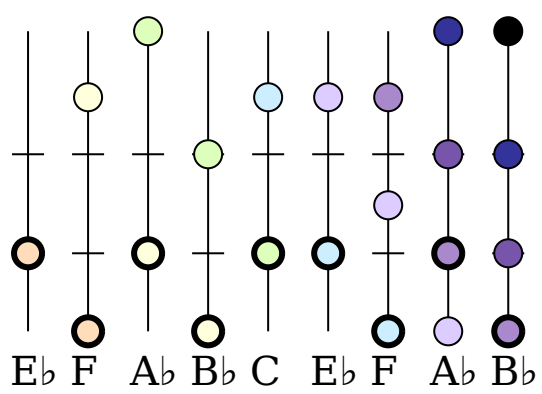

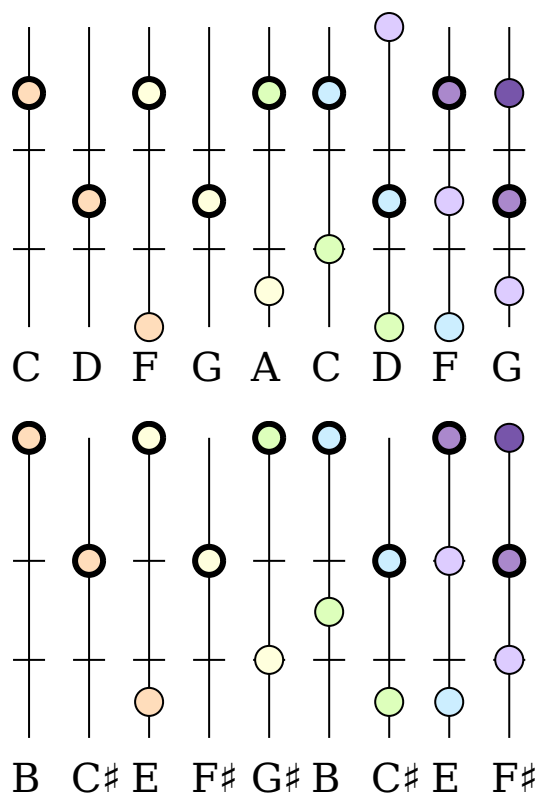

Topologie

Voici un schéma qui tente une visualisation des positions alternatives au trombone.

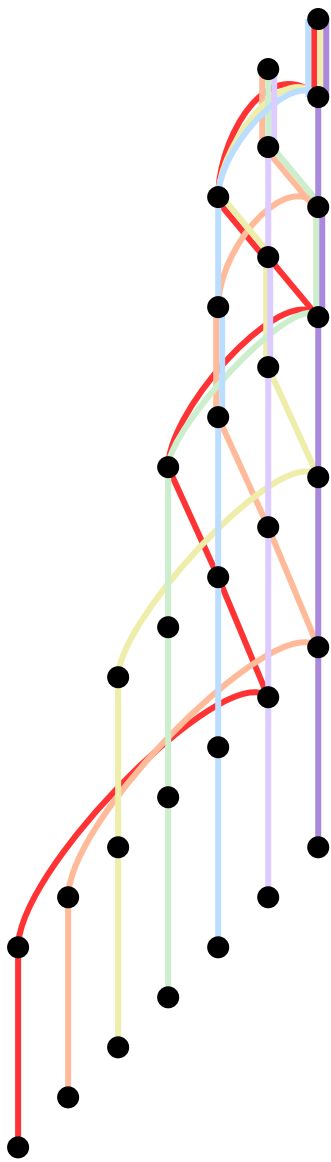

Contact

Pour toute remarque ou suggestion, vous pouvez :

- créer un ticket sur [Github](#) ;
- envoyer un mail à profgra.org@gmail.com.